

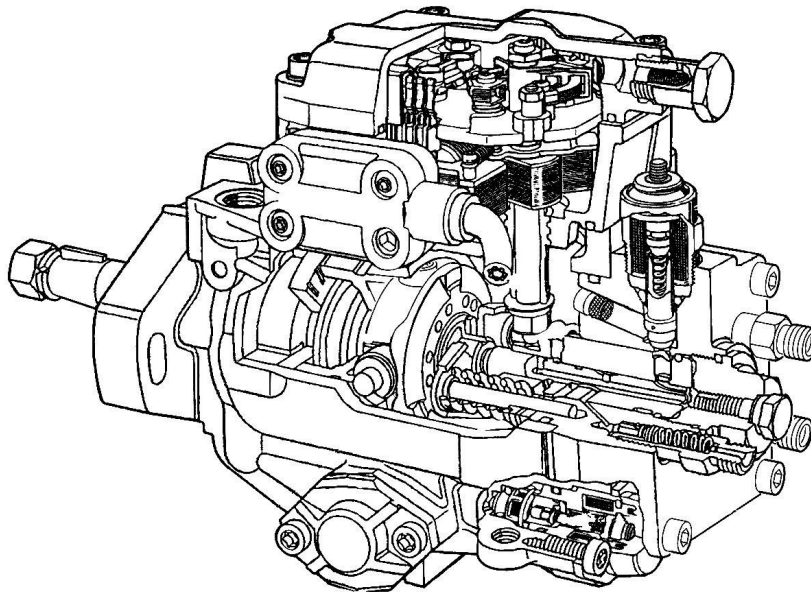

Training Manual

Advanced Diesel Engine Management

CT-L3004



MME Technical Training 2004



ZOOM-ZOOM

No part of this hardcopy may be reproduced in any form without prior permission of Mazda Motor Europe GmbH.

The illustrations, technical information, data and descriptive text in this issue, to the best of our knowledge, were correct at the time of going to print.

No liability can be accepted for any inaccuracies or omissions in this publication, although every possible care has been taken to make it as complete and accurate as possible.

© 2004
Mazda Motor Europe GmbH
Technical Training Department

Introduction	00-1
Zexel Injection Pump System.....	01-1
Features.....	01-1
Intake-air System.....	01-2
Features.....	01-2
Parts Location.....	01-3
System Overview.....	01-4
Turbocharger.....	01-5
Fuel System	01-7
Parts Location.....	01-7
System Overview.....	01-8
Injection Pump.....	01-9
Low-pressure System.....	01-10
Features.....	01-10
High-pressure System.....	01-10
Features.....	01-10
Axial-piston Distributor Pump.....	01-11
Pressure Valves.....	01-13
Injectors.....	01-14
Diagnostics.....	01-16
Injection Amount Control.....	01-17
Features.....	01-17
Electronic Governor.....	01-18
Control Sleeve Position Sensor.....	01-21
Injection Pump PROM.....	01-23
Fuel Shut-off Valve.....	01-24
Diagnostics.....	01-25
Injection Timing Control.....	01-26
Features.....	01-26
Timer Device.....	01-27
Timer Control Valve.....	01-28
Timer Position Sensor.....	01-30
Pump Speed Sensor.....	01-32
Diagnostics.....	01-33
Emission System.....	01-34
Parts Location.....	01-34
System Overview.....	01-35
Exhaust System.....	01-36
Features.....	01-36
Exhaust Gas Recirculation System.....	01-36
Features.....	01-36
Intake Shutter Valve.....	01-37
Diagnostics.....	01-38

Control System	01-39
Parts Location	01-39
Block Diagram.....	01-40
Relationship Chart	01-42
Powertrain Control Module.....	01-43
Features	01-43
Sensors.....	01-43
Features	01-43
Crankshaft Position Sensor	01-44
Actuators.....	01-46
Features	01-46
Immobilizer System	01-46
Denso Injection Pump System	02-1
Features.....	02-1
Intake-air System	02-2
Features.....	02-2
Parts Location	02-3
System Overview	02-4
Fuel System	02-5
Parts Location	02-5
System Overview	02-6
Injection Pump	02-7
Low-pressure System	02-8
Features	02-8
High-pressure System.....	02-9
Features	02-9
Axial-piston Distributor Pump	02-9
Injectors	02-12
Diagnostics	02-13
Injection Amount Control.....	02-14
Features	02-14
Spill Valve.....	02-14
Injector Driver Module.....	02-17
Fuel Shut-off Valve	02-20
Diagnostics	02-21
Injection Timing Control	02-22
Features	02-22
Pump Speed Sensor.....	02-22
Diagnostics	02-24

Emission System	02-25
Parts Location	02-25
System Overview	02-26
Exhaust System	02-27
Features	02-27
Exhaust Gas Recirculation System.....	02-27
Features	02-27
Control System	02-28
Parts Location	02-28
Block Diagram.....	02-29
Relationship Chart	02-31
Powertrain Control Module.....	02-32
Features	02-32
Sensors.....	02-32
Features	02-32
Crankshaft Position Sensor	02-33
Actuators.....	02-35
Features	02-35
Immobilizer System	02-36
On-board Diagnostic System	03-1
General	03-1
Malfunction Indicator Light	03-2
Data Link Connector	03-3
Diagnostic Trouble Codes	03-5
DTC Status	03-6
Fault Detection Function	03-7
Monitoring Strategy for Sensors.....	03-7
Monitoring Strategy for Actuators.....	03-9
Monitoring Strategy for PCM.....	03-11
Fail-safe Function	03-11
Fail-safe Strategy for Sensors.....	03-11
Fail-safe Strategy for Actuators.....	03-12
European On-board Diagnostics	03-13
General	03-13
Type Approval and Testing	03-13
Definitions	03-15
Monitors	03-16
MIL Activation and Fault Storage	03-21
Freeze Frame Data	03-25
Tamper Protection	03-27
Diagnostics	03-28

Engine Mechanical System04-1
 General 04-1
 Compression Pressure 04-1
 Valve Timing 04-2
 Valve Clearance..... 04-3
 Diagnostics 04-4

Diagnostic Process.....05-1
 General 05-1
 Basic Checks for Troubleshooting 05-2

List of Abbreviations.....06-1

Introduction

- Ever stricter exhaust and noise emission regulations and the demand for low fuel consumption impose increasing demands on the fuel injection system of the diesel engine. In order to fulfill these requirements the mechanically controlled diesel injection systems have been superseded by electronically controlled systems. While the Common Rail Systems used on Mazda vehicles have already been covered by the course “Basic Diesel Engine Management” (CT-L2005) this course describes the more complex Injection Pump Systems, which require comprehensive system knowledge.
- The following fuel injection systems are covered in this course:
 - Zexel injection pump system (B2500 UN with WL-3 or WLT-3 engine)
 - Denso injection pump system (323 BJ, 626 GF/GW and Premacy CP with RF-T engine)

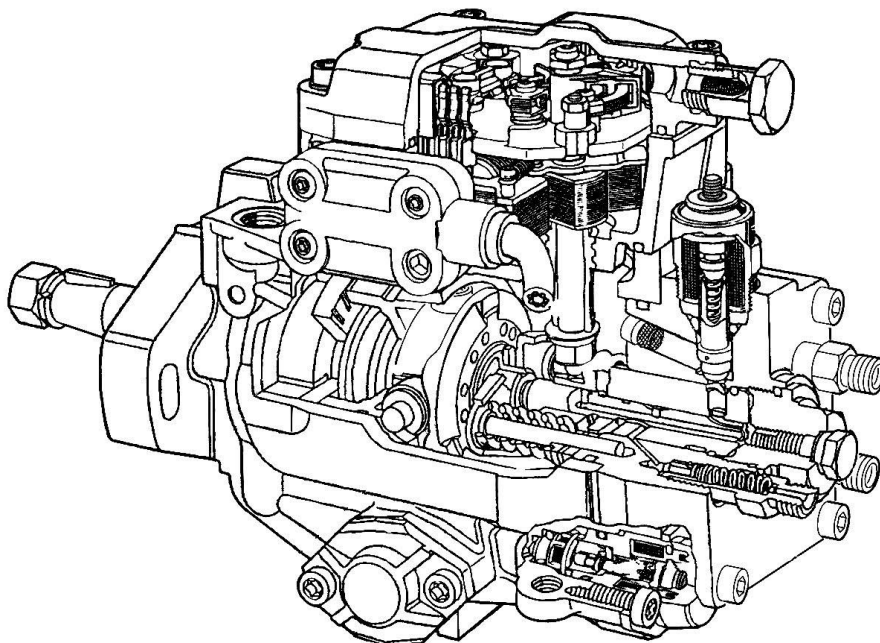

Zexel P

- In addition, this training course provides information about the following items:
 - On-board diagnostic system (incl. European on-board diagnostics)
 - Engine mechanical system
 - Diagnostic process

Notes

Zexel Injection Pump System

Zexel Injection Pump System

Features

- The B2500 UN with WL-3/WLT-3 engine is equipped with the Zexel injection pump system NP-VE4. This system has the following features:
 - Axial piston-type injection pump with electronic governor
 - One-spring injectors
 - Injection pump pressure of max. 80 MPa

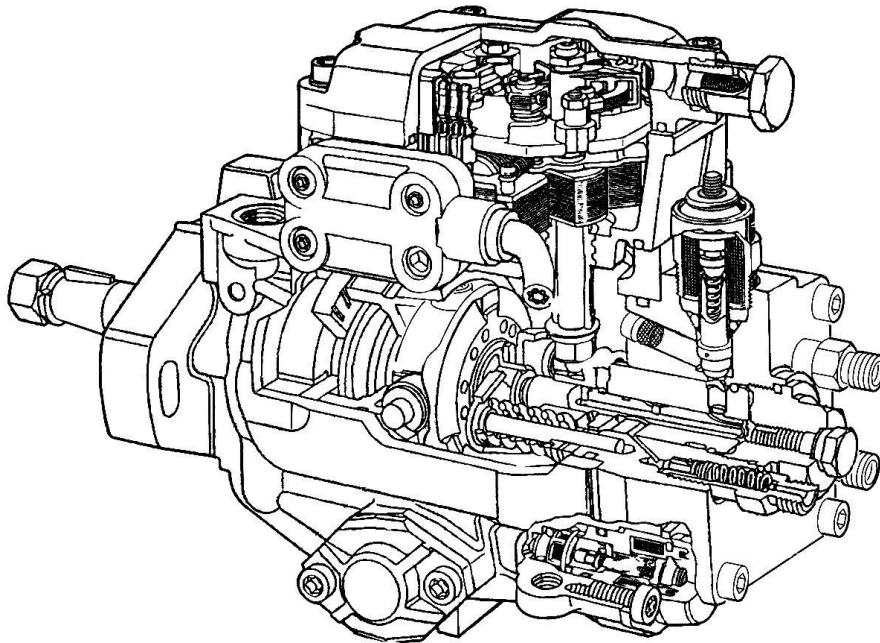

Zexel P

NOTE: Some of the components of the Zexel injection pump system are very similar in design and operation to those of the common rail systems. Therefore this section only describes the components which are new or operate in a different way to those of the common rail systems.

Intake-air System

Features

- The intake-air system of the Zexel injection pump system has the following features:
 - Hot wire-type mass air flow sensor with integrated intake air temperature sensor (similar to that of the Denso common rail system)
 - Turbocharger with fixed geometry turbine and boost pressure control valve with spring-loaded damper for vehicles with WL-3 engine
 - Turbocharger with fixed geometry turbine and boost pressure control valve with pressure actuator for vehicles with WLT-3 engine (similar to that of the Bosch common rail system)
 - Charge-air cooler (similar to that of the Denso common rail system)
 - Manifold absolute pressure sensor (similar to that of the Denso common rail system)
 - Intake air temperature sensor (similar to that of the Denso common rail system)
 - Variable swirl control valves have been cancelled.

Parts Location

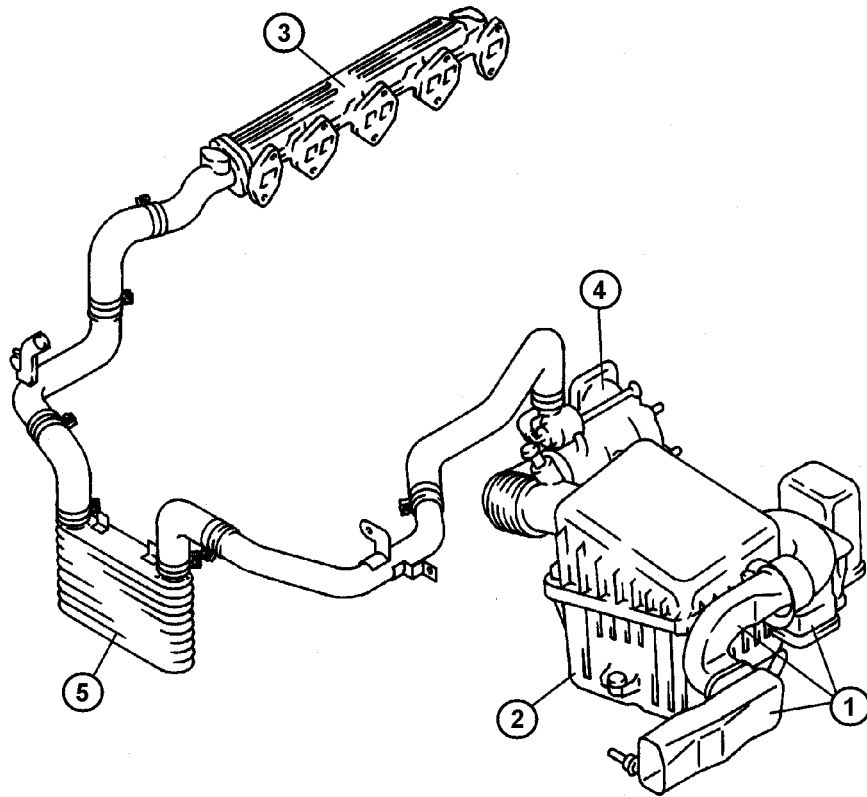

M 333 F2-13

- 1 Fresh-air duct
- 2 Air cleaner
- 3 Intake manifold

- 4 Turbocharger
- 5 Charge-air cooler

System Overview

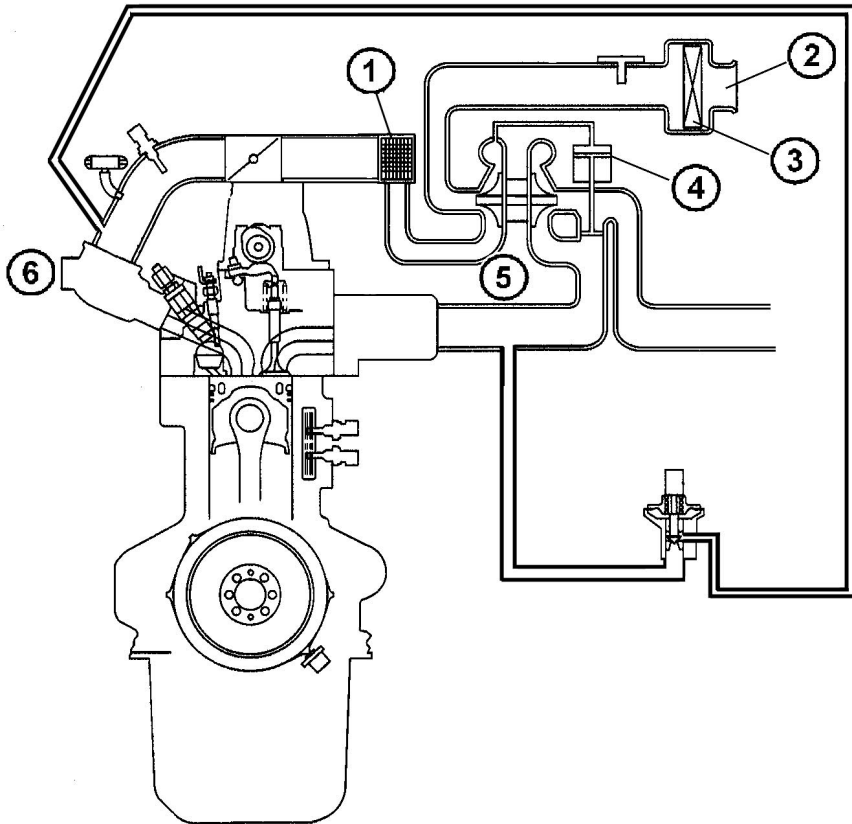

M 1724 F2-18-m

- 1 Charge-air cooler
- 2 Fresh-air duct
- 3 Air cleaner

- 4 Boost pressure control valve
- 5 Turbocharger
- 6 Intake manifold

Turbocharger

- On the B2500 UN with WL-3 engine the turbocharger features a boost pressure control valve with a spring-loaded damper. The boost pressure control valve is actuated by the exhaust-gas pressure and varies the exhaust-gas flow through the turbine.
- If the boost pressure on the turbine-side of the turbocharger exceeds a certain limit, the boost pressure control valve opens. As a result, a part of the exhaust-gas flow is ducted past the turbine, reducing the mass flow through the turbine and hence the boost pressure.

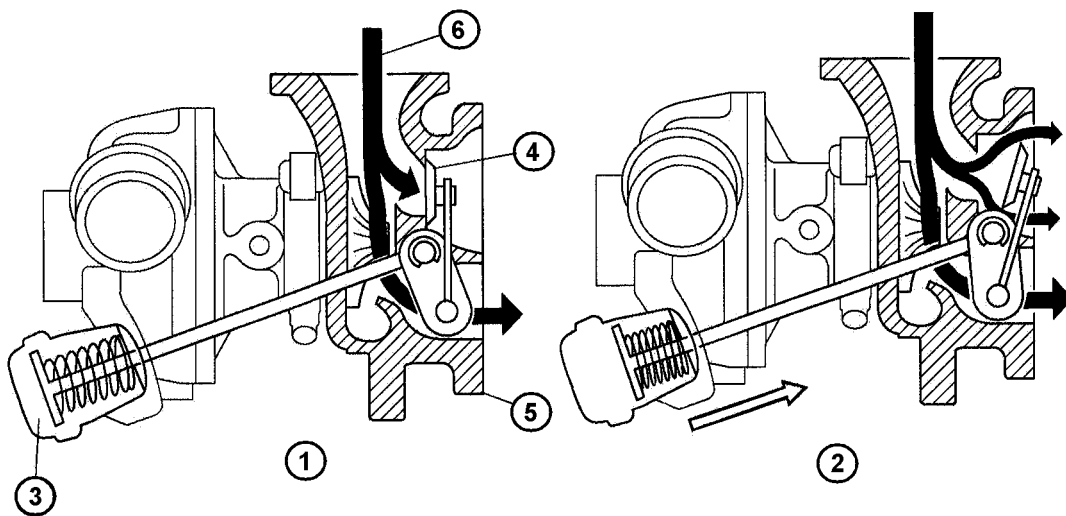

M 1724 F2-9

- 1 Low exhaust gas pressure
- 2 High exhaust gas pressure
- 3 Damper

- 4 Boost pressure control valve
- 5 Turbocharger
- 6 Exhaust gas flow

Diagnostics

- The turbocharger can be checked as following:
 - Monitoring the boost pressure via the PID **MAP** (Press/Volt)
 - Checking the turbocharger (similar to the Denso common rail system)
 - Checking the boost pressure on vehicles with WL-3 engine
 - Checking the boost pressure on vehicles with WLT-3 engine (similar to the Bosch common rail system)
 - Checking the boost pressure control valve on vehicles with WLT-3 engine (similar to the Bosch common rail system)

Checking the boost pressure on vehicles with WL-3 engine

- Connect the PVT (with the aid of the FHA) to the hose between intake manifold and MAP sensor. Then check the boost pressure during a road test since a load is necessary for this.

Fuel System

Parts Location

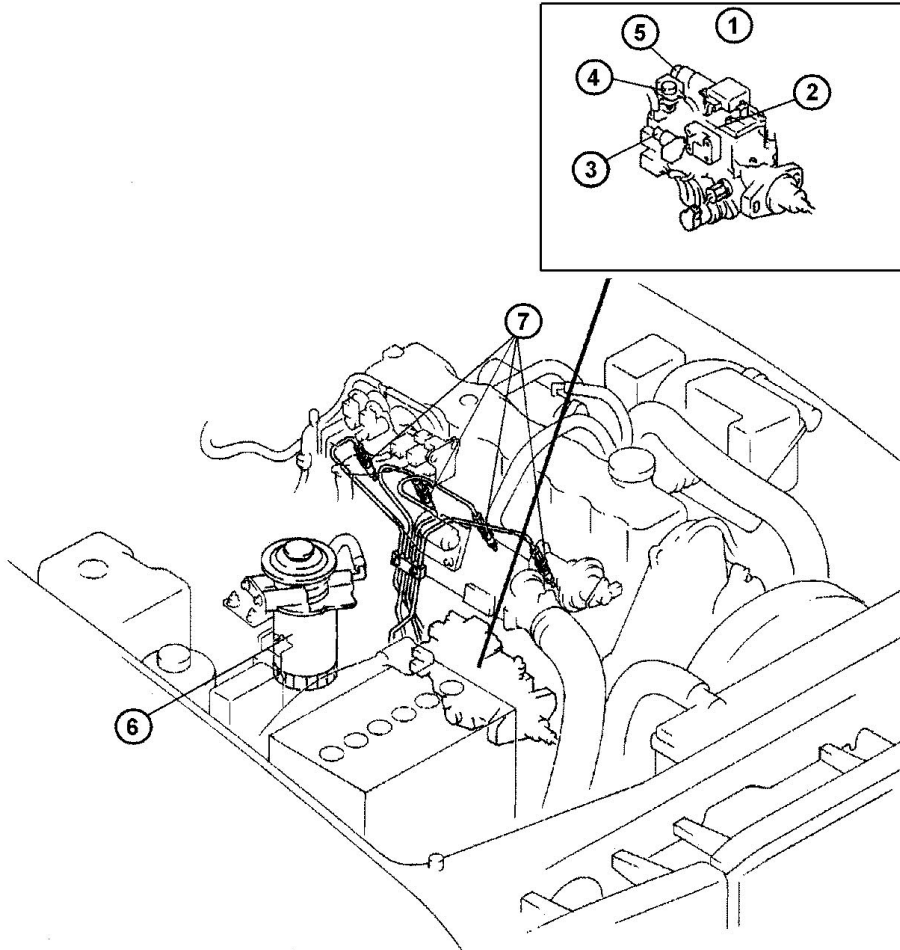

M 1724 F2-11

- 1 Injection pump
- 2 Electronic governor
- 3 Timer control valve
- 4 Fuel shut-off valve

- 5 Overflow throttle valve
- 6 Fuel filter
- 7 Injector

System Overview

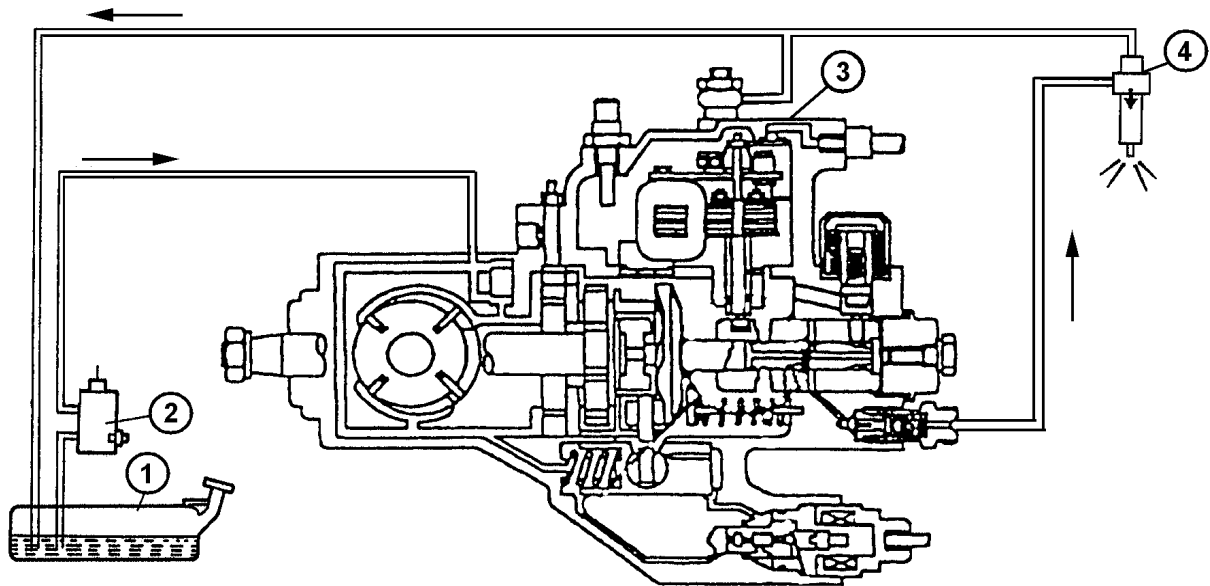

N ECCS S6

- 1 Fuel tank
- 2 Fuel filter

- 3 Injection pump
- 4 Injector

Injection Pump

- The NP-VE4 injection pump system features an axial piston-type injection pump manufactured by Zexel.

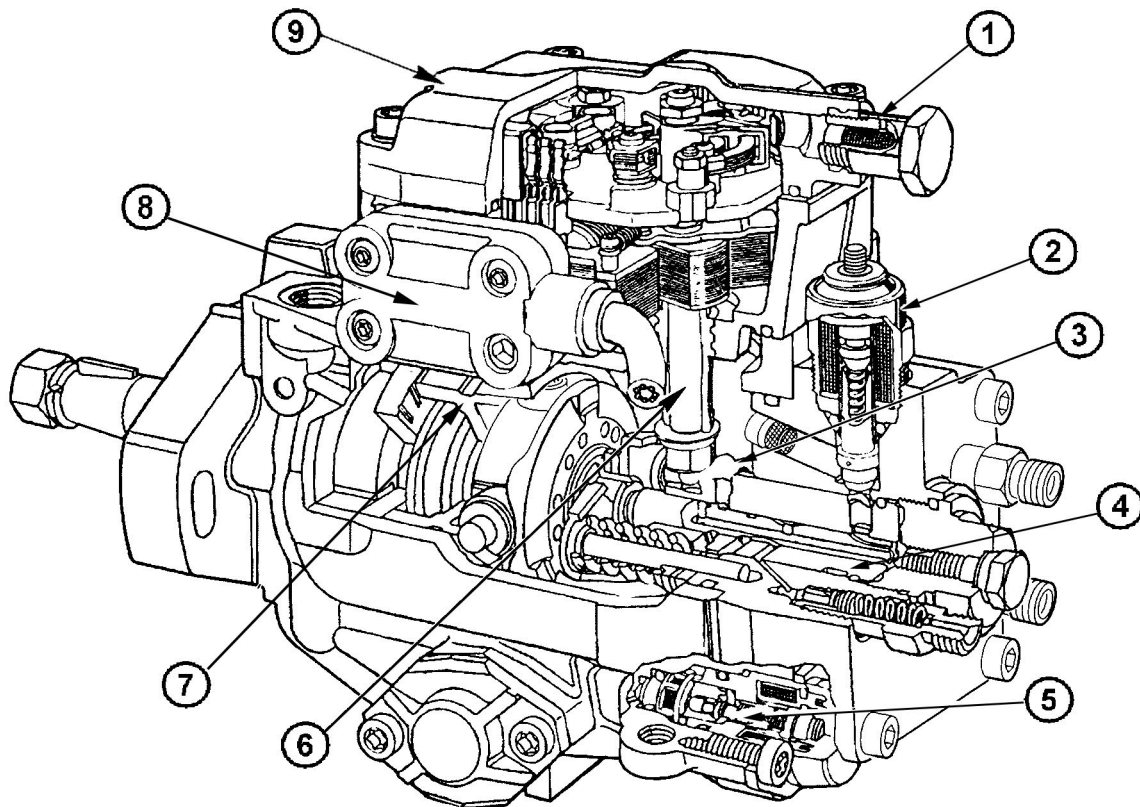

F CG 7662 ST 260 11

- | | | | |
|---|-------------------------|---|--------------------------------------|
| 1 | Overflow throttle valve | 6 | Control shaft |
| 2 | Fuel shut-off valve | 7 | Roller ring |
| 3 | Control sleeve | 8 | Connector with integrated FLT sensor |
| 4 | Distributor plunger | 9 | Electronic governor |
| 5 | Timer control valve | | |

Low-pressure System

Features

- The low-pressure system of the vehicles with WL-3/WLT-3 engine has the following features:
 - Fuel filter with priming pump and water level sensor (similar to that of the Denso common rail system)
 - Fuel warmer controlled by a vacuum switch (similar to that of the Denso common rail system)
 - Vane-type feed pump (similar to that of the Siemens common rail system)
 - Pressure control valve (similar to that of the Denso common rail system)
 - Overflow throttle valve (similar to that of the Denso common rail system)

High-pressure System

Features

- The high-pressure system of the vehicles with WL-3/WLT-3 engine has the following features:
 - Axial piston-type distributor pump with control sleeve has been introduced.
 - Pressure valves have been introduced.
 - One-spring injectors have been introduced.

Axial-piston Distributor Pump

- The axial-piston distributor pump produces the high-pressure and conveys the fuel to the injectors. It is located in the injection pump and consists of drive shaft, roller ring, distributor plunger with cam plate and control sleeve.

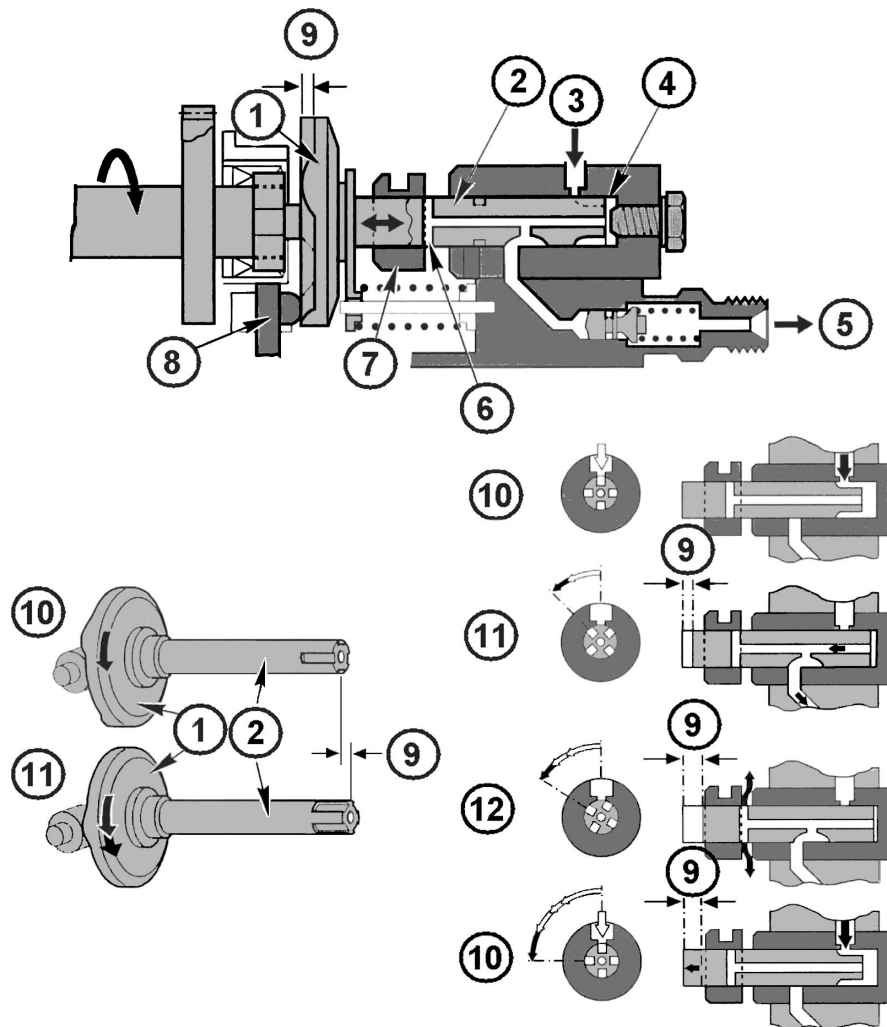

F 7662 ST 260 83

- | | | | |
|---|-----------------------|----|----------------------------|
| 1 | Cam plate | 7 | Control sleeve |
| 2 | Distributor plunger | 8 | Roller ring |
| 3 | From pump chamber | 9 | Stroke |
| 4 | High-pressure chamber | 10 | Filling phase |
| 5 | To fuel injector | 11 | High-pressure phase |
| 6 | Cut-off bore | 12 | End of high-pressure phase |

- The distributor plunger with the cam plate is connected to the drive shaft and rotates with half the engine speed, while the roller ring stands still. As the spring-loaded cam plate is forced against the roller ring, the cam lobes riding on the roller ring convert the purely rotational movement of the drive shaft into a rotating-reciprocating movement of the plunger. Due to this the distributor plunger is forced upwards to its TDC position by the cams on the cam plate, and the two pressure springs force it back down again to its BDC position.
- The distributor plunger runs in the control sleeve, which can be adjusted axially and opens or closes a transverse cut-off bore in the plunger. The cut-off bore connects the high-pressure chamber to the pump chamber.
- As the distributor plunger moves from TDC to BDC, the plunger's transverse cut-off bore is closed by the control sleeve and fuel flows through the open inlet passage into the high-pressure chamber (= filling phase).
- At BDC the plunger's rotating movement then closes the inlet passage and the distributor slot opens a certain outlet port. When the plunger moves from BDC to TDC (= working stroke), fuel is compressed in the high-pressure chamber (= high-pressure phase). As the pressure rises in the high-pressure chamber and in the outlet port passage, the pressure valve in question opens and fuel is forced through the high-pressure line to the injector.
- The working stroke is completed as soon as the plunger's transverse cut-off bore comes out of the control sleeve, returning the surplus fuel to the pump chamber (= end of high-pressure phase). As the pressure in the high-pressure chamber decreases, the pressure valve closes the high-pressure line and no more fuel is delivered to the injector.

Pressure Valves

- The pressure valves ensure precise closing of the injector and prevent secondary injection. The valves are located at the distributor head of the injection pump and consist of a spring-loaded plunger and a spring-loaded plate with return-flow throttle.
- When the pressure from the injection pump is lower than the pressure in the high-pressure line at the end of the high-pressure phase, the plunger closes and a defined volume of fuel is removed from the high-pressure line. As a result, the pressure in the high-pressure line is relieved and the injector closes precisely.
- In addition, the return-flow throttle damps the pressure waves, which are generated in the high-pressure line due to the pressure relief. Otherwise the pressure waves would be reflected at the pressure valve, causing the valve to open again or generating a vacuum in the high-pressure line. This would lead to secondary injection with attendant increases in exhaust emissions, or to cavitation and wear at the high-pressure line and at the injector.

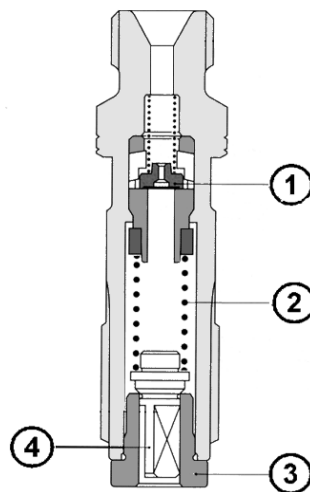

UMK1183Y-Z

- 1 Plate with return-flow throttle
- 2 Spring

- 3 Valve holder
- 4 Plunger

Injectors

- The B2500 UN with WL-3/WLT-3 engine features one-spring injectors, which consist of nozzle body with nozzle needle, pressure pin and spring.

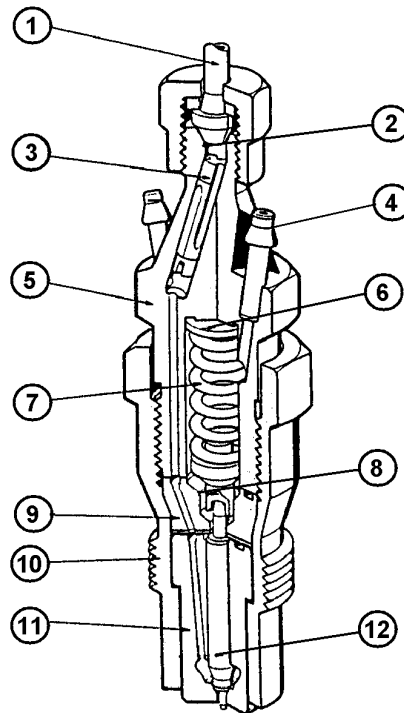

NE S28

- | | | | |
|---|------------------------|----|----------------------|
| 1 | High-pressure line | 7 | Nozzle spring |
| 2 | Inlet passage | 8 | Pressure pin |
| 3 | Edge-type filter | 9 | Intermediate element |
| 4 | Return-flow connection | 10 | Nozzle retaining nut |
| 5 | Nozzle body | 11 | Nozzle |
| 6 | Adjustment shim | 12 | Nozzle needle |

- The nozzle is closed by the spring force, which presses the nozzle needle against the nozzle body. The fuel delivered from the injection pump is passed through the inlet channel to the nozzle chamber, where the fuel pressure acts on the pressure shoulder of the nozzle needle. When the hydraulic force on the pressure shoulder exceeds the spring force, the nozzle needle is lifted and the fuel injection starts. The injection ends as soon as the fuel pressure drops far enough for the nozzle spring to force the nozzle needle back onto its seat.

- The one-spring injectors are equipped with a throttling pintle nozzle, which varies the spray pattern during injection process. When the nozzle needle lifts it first of all opens a small annular gap, so that only a small amount of fuel is injected (= initial spray). Since the injection pump delivers more fuel than can flow through the small gap, the pressure in the injector rises. Due to this the needle lift increases also, widening the spray orifice until the major amount of fuel is injected towards the end of the needle lift (= main spray).
- As a result, the pressure in the combustion chamber rises less sharply so that the combustion is smoother and though quieter.

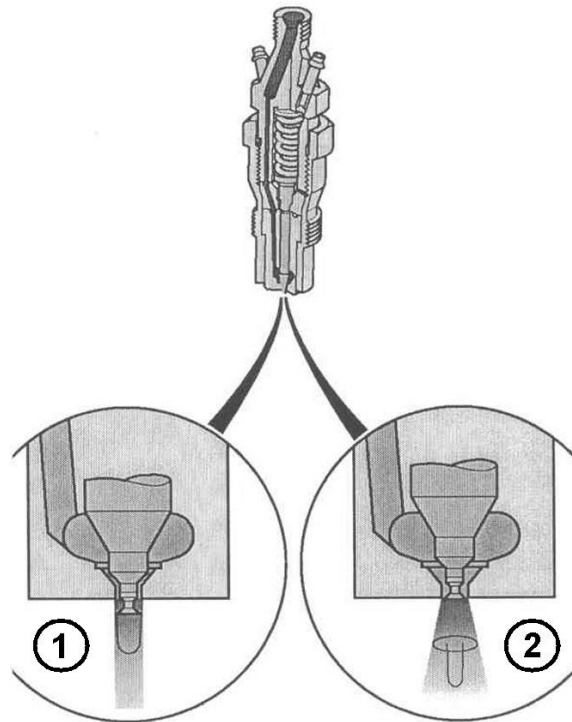

F 7662 ST 132

1 Initial spray

2 Main spray

Diagnostics

- The high-pressure system can be checked as following:
 - Checking the start of fuel delivery
 - Checking the low-pressure part of the injection pump
 - Checking the function of the injectors

Checking the low-pressure part of the injection pump

- Disconnect the connector of the electronic governor (to prevent fuel injection). Then disconnect the fuel return line at the injection pump and connect a locally fabricated fuel line to the pump. The other end of this fuel line must go to a measuring container. Then crank the engine for approx. 10 s and check the amount of fuel delivered. If the fuel amount is far below or far above the reference value, the injection pump might be faulty.

NOTE: This test should only be performed, if the diagnostic check revealed that the low-pressure system from the fuel tank to the injection pump is intact.

Checking the function of the injectors

- Switch off the engine and release the high-pressure line of an injector. Then start the engine and check, whether the engine speed drops (and if so, how much it drops) and whether fuel escapes between high-pressure line and injector. Repeat this procedure for all injectors and note the values.
- If the drop in engine speed at a certain cylinder is lower than on the other cylinders and fuel escapes, the injector concerned or the base engine might be faulty. In order to rule out a faulty base engine, check the compression of the engine before replacing the injector. If the engine speed drop at a certain cylinder is lower than on the other cylinders and no or comparatively less fuel escapes, the injection pump might be faulty.

Injection Amount Control

Features

- The injection amount control of the vehicles with WL-3/WLT-3 engine has the following features:
 - Electronic governor with direct current motor and control sleeve position sensor has been introduced.
 - Injection pump PROM has been introduced.
 - Fuel shut-off valve has been introduced.
 - Fuel temperature sensor integrated in the injection pump (similar to that of the Denso common rail system)

Electronic Governor

- The electronic governor controls the axial position of the control sleeve on the distributor plunger and hence the fuel amount delivered to the injectors. As a result, the injection amount varies depending on the operating conditions of the engine. The governor is located in the injection pump cover and is driven by a DC motor.

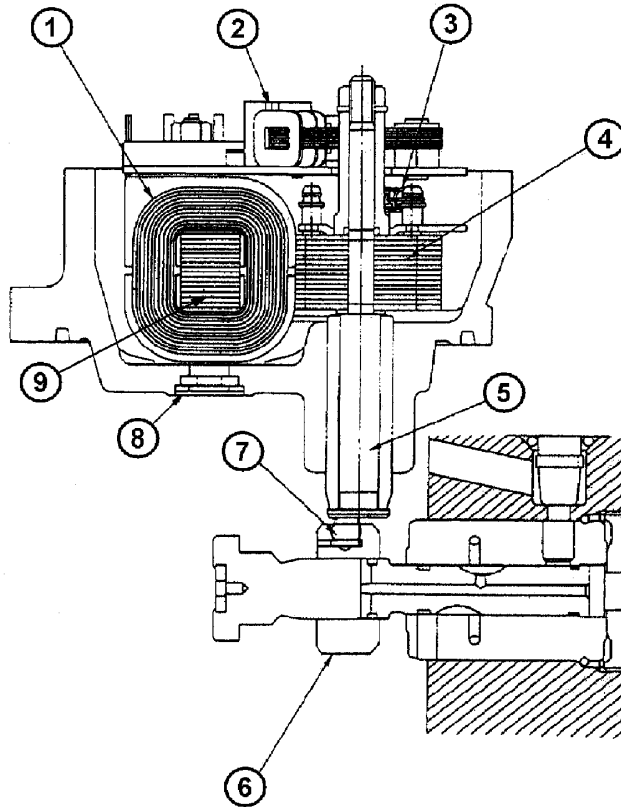

M 1588 F6-12

- | | | | |
|---|--------------------------------|---|----------------------|
| 1 | Coil | 6 | Control sleeve |
| 2 | Control sleeve position sensor | 7 | Eccentric pin |
| 3 | Return spring | 8 | Magnetic-type filter |
| 4 | Rotor | 9 | Stator |
| 5 | Control shaft | | |

- The position of the control sleeve is controlled by the PCM, which activates the DC motor via a duty signal.

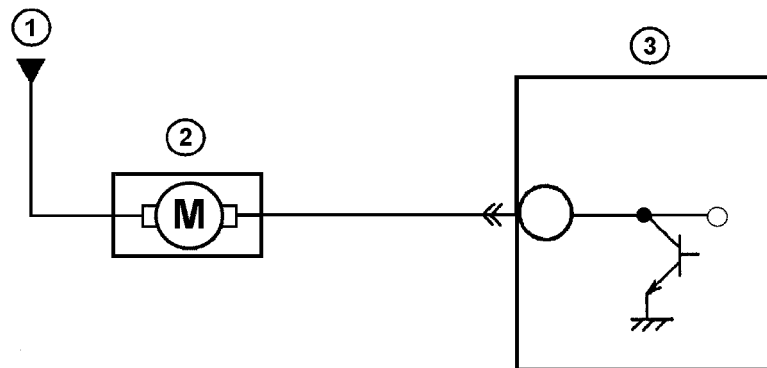

2005_062-B

- 1 From PCM control relay
- 2 DC motor

3 PCM

- When the required injection amount is small the PCM controls the DC motor with a small duty cycle, so that the control sleeve moves by a short distance. Thus the transverse cut-off bore is opened early during the high-pressure phase, resulting in a small injection amount.
- When the required injection amount is large the PCM controls the DC motor with a large duty cycle, so that the control sleeve moves by a long distance. Thus the transverse cut-off bore is opened late during the high-pressure phase, resulting in a large injection amount.
- In addition, the electronic governor serves as a standby shut-off in case the fuel shut-off valve should fail, i.e the PCM de-energizes the DC motor a few seconds after the ignition is switched off. The force of the return springs causes the control sleeve to adopt in the parked position, setting the injection amount to zero.

NOTE: When the electronic governor fails the control sleeve adopts in the parked position and sets the injection amount to zero. As a result, the engine stalls and does not start anymore.

- The PCM controls the electronic governor by a duty signal 0 V/12 V.

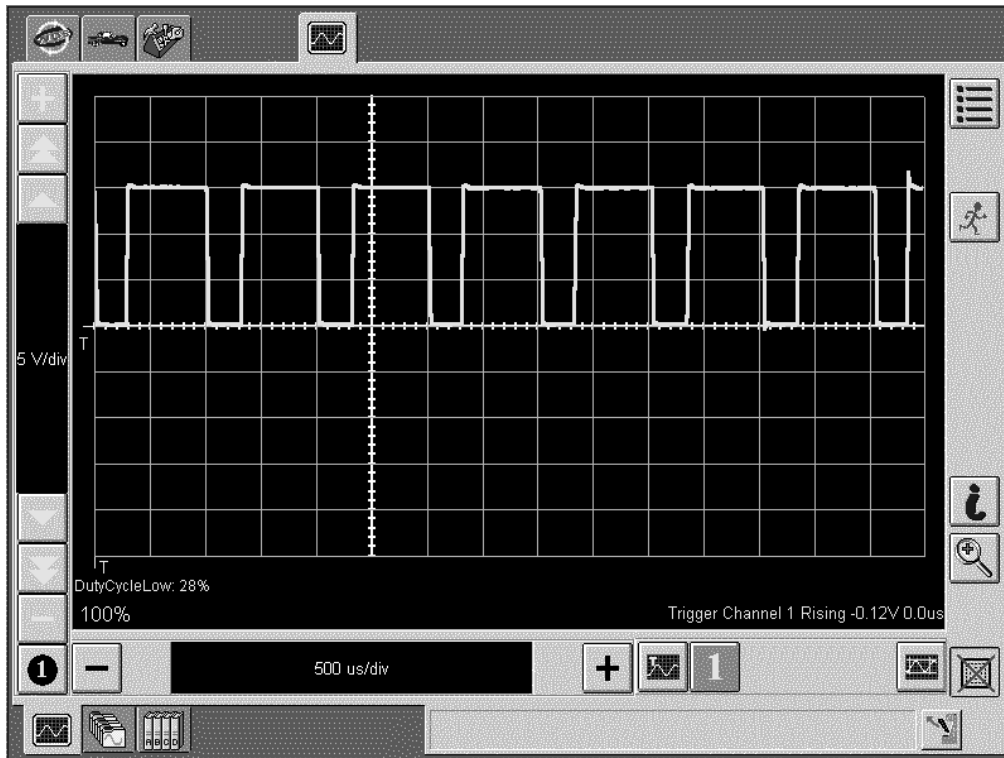

GOV Signal

Control Sleeve Position Sensor

- The **CSP (Control Sleeve Position)** sensor detects the axial position of the control sleeve on the distributor plunger, giving a feedback about the actual injection amount to the PCM. The sensor is integrated in the electronic governor and consists of an iron core, two coils and two short-circuit rings.
- The PCM supplies the coils with a constant alternating current, generating a magnetic field. This magnetic field is shielded by the short-circuit rings. The measuring short-circuit ring is joint to the control shaft of the governor and moves on the iron core, when the shaft rotates. As a result, the magnetic field and hence the voltage of the measuring coil changes.
- The reference short-circuit ring is fixed on the iron core. As a result, the magnetic field and hence the voltage of the reference coil is constant. The PCM calculates an accurate rotation angle of the control shaft by comparing the voltage values of both coils and thereby detects the position of the control sleeve.

NOTE: When the CSP sensor fails, the engine stalls and does not start anymore.

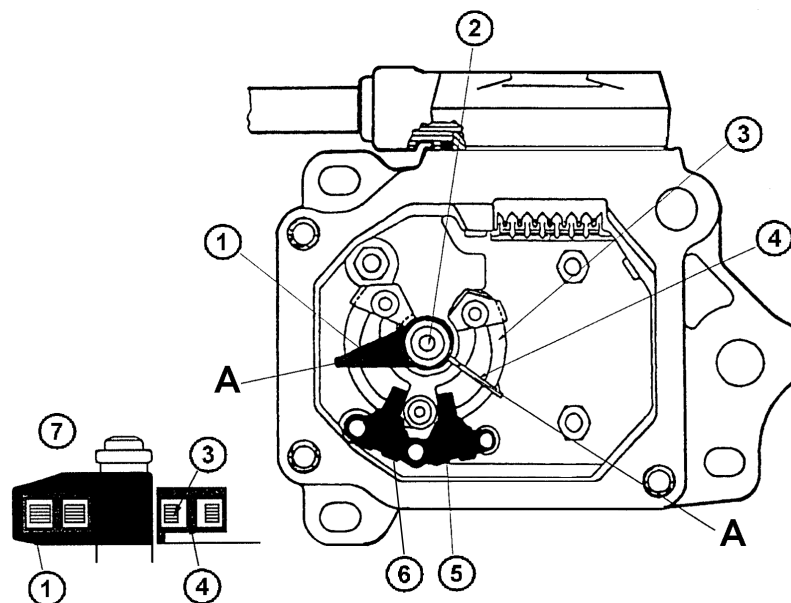

N ECCS 7

- | | | | |
|---|------------------------------|---|----------------|
| 1 | Measuring short-circuit ring | 5 | Reference coil |
| 2 | Control shaft | 6 | Measuring coil |
| 3 | Iron core | 7 | Cut view A-A |
| 4 | Reference short-circuit ring | | |

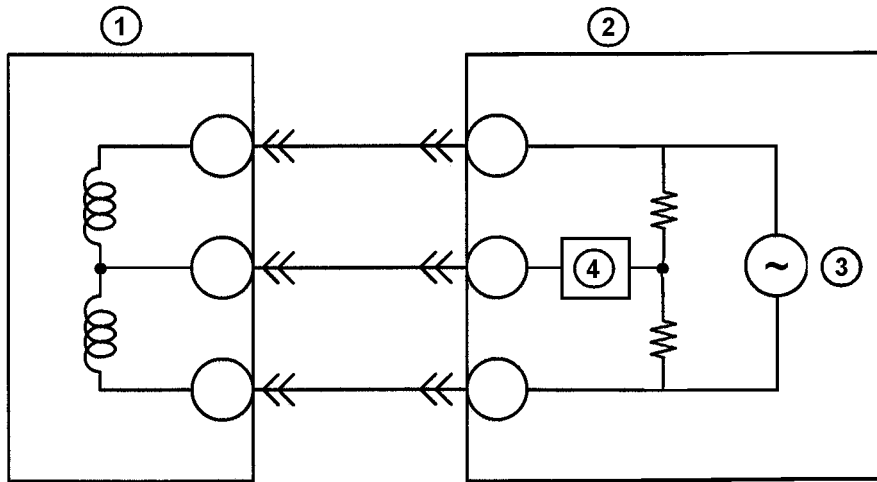

M 1724 F2-111

- 1 CSP sensor
- 2 PCM

- 3 Voltage supply
- 4 Voltage detection circuit

Injection Pump PROM

- Inside the injection pump there are various components, which have manufacturing tolerances. As these tolerances affect the injection amount, they are taken into account by the injection pump **PROM** (**P**rogrammable **R**ead **O**nly **M**emory). The information stored on the PROM is determined during injection pump production.
- The injection pump PROM is located on the injection pump cover. The information of the PROM is used to compensate the injection amount deviations of the pump, improving engine running, combustion noise and exhaust emissions.

NOTE: The injection pump PROM matches exactly the characteristics of the individual injection pump. If the PROM is faulty or damaged, contact a local dealer of the injection pump supplier.

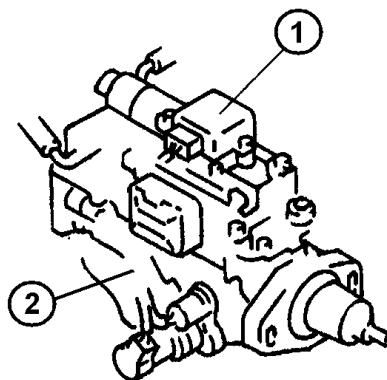

M 1724 F2-31

1 Injection pump PROM

2 Injection pump

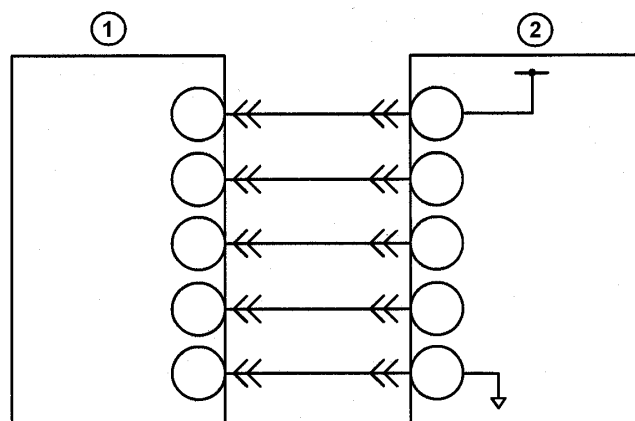

M 1724 F2-126

1 Injection pump PROM

2 PCM

Fuel Shut-off Valve

- The **FSOV (Fuel Shut-Off Valve)** interrupts the fuel flow in the inlet passage to the high-pressure chamber, so that the engine stops when the ignition is switched off. The valve is located at the distributor head of the injection pump and consists of a coil and a spring-loaded plunger. The position of the plunger is controlled by the PCM, which activates the FSOV via an ON/OFF signal.

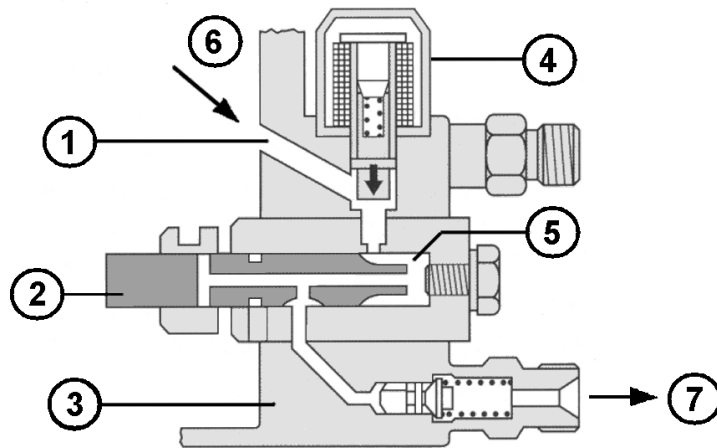

BE S44 B17

- | | | | |
|---|---------------------|---|-----------------------|
| 1 | Inlet passage | 5 | High-pressure chamber |
| 2 | Distributor plunger | 6 | From pump chamber |
| 3 | Distributor head | 7 | To injector |
| 4 | FSOV | | |

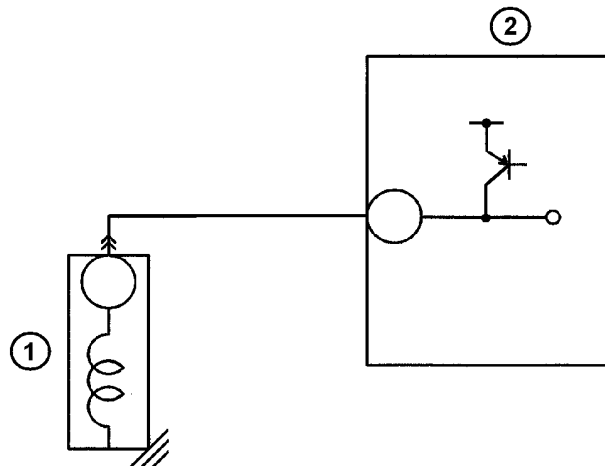

M 1724 F2-108

- | | | | |
|---|------|---|-----|
| 1 | FSOV | 2 | PCM |
|---|------|---|-----|

- When the engine is started, the PCM energizes the FSOV, so that the inlet passage to the high-pressure chamber is open. Thus fuel is supplied to the high-pressure chamber, enabling the engine to start.
- When the ignition is switched off, the PCM de-energizes the FSOV, so that the inlet passage to the high-pressure chamber is closed. Thus the fuel supply to the high-pressure chamber is cut off, stopping the engine.

NOTE: When the FSOV fails, the plunger adopts in the closed position. As a result the engine stalls and does not start anymore.

Diagnostics

- The components of the injection amount control can be checked as following:
 - Activating the electronic governor via the PID **GOVERNOR#** (Per)
 - Checking the voltage signal of the electronic governor
 - Checking the resistance of the electronic governor
 - Monitoring the CSP sensor via the PID **CSP** (Volt)
 - Checking the voltage signal of the CSP sensor
 - Checking the resistance of the CSP sensor
 - Monitoring the FLT sensor via the PID **FLT/FLT V** (Temp/Volt)
 - Checking the voltage of the FLT sensor
 - Checking the resistance of the FLT sensor
 - Monitoring the FSOV via the PID **FSOV#** (Mode)
 - Checking the voltage of the FSOV
 - Checking the resistance of the FSOV

Injection Timing Control

Features

- The injection timing control of the vehicles with WL-3/WLT-3 engine has the following features:
 - Timer device with timer control valve and position sensor has been introduced.
 - Pump speed sensor mounted on the injection pump housing has been introduced.

Timer Device

- The timer device controls the injection timing depending on the engine speed. The device is located in a separate housing on the bottom of the injection pump and consists of the timer piston, pin and spring.
- The timer piston features a bore, so that the fuel pressure from the pump chamber acts on the high-pressure side of the piston. The low-pressure side of the piston is connected to the suction side of the feed pump.
- If the pressure in the pump chamber rises with increasing engine speed, the hydraulic force on the timer piston overcomes the spring force and the piston moves into the direction of the spring. The pin converts the longitudinal movement of the piston into a rotational movement of the roller ring. Thus the relative position of the roller ring to the cam plate changes, so that the rollers lift the rotating cam plate earlier (advanced injection timing).

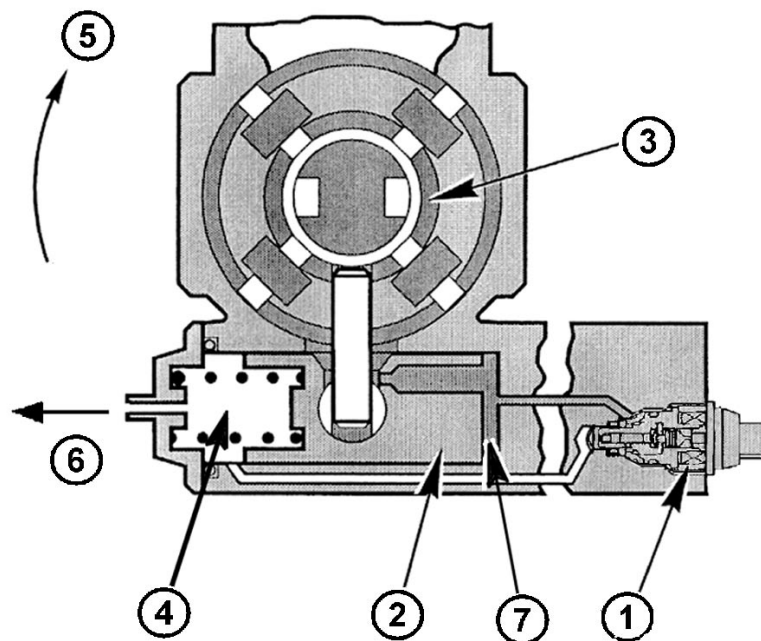

F CG 7664 ST 192 94 S59 second

- 1 Timer control valve
- 2 Timer piston
- 3 Roller ring
- 4 Low-pressure side

- 5 Injection timing advanced
- 6 To feed pump
- 7 High-pressure side

Timer Control Valve

- The **TCV (Timer Control Valve)** controls the pressure on the high-pressure side of the timer piston and hence the position of the roller ring. As a result, the injection timing varies depending on the operating conditions of the engine. The valve is located in a passage between the high-pressure side and the low-pressure side of the timer piston, and consists of a coil and a spring-loaded plunger.

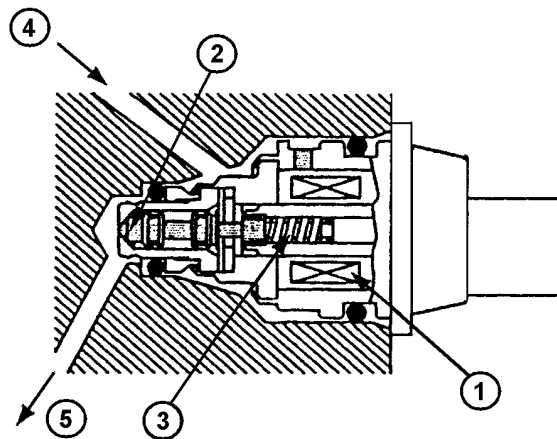

N ECCS S8 li

- | | | | |
|---|---------|---|-------------------------|
| 1 | Coil | 4 | From high-pressure side |
| 2 | Plunger | 5 | To low-pressure side |
| 3 | Spring | | |

- The position of the plunger is controlled by the PCM, which activates the TCV via a duty signal.

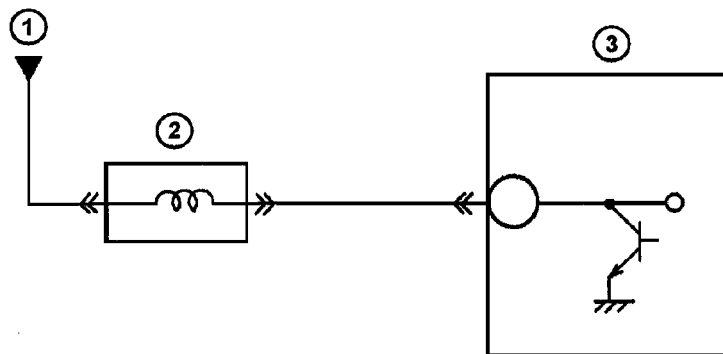

E51178

- | | | | |
|---|------------------------|---|-----|
| 1 | From PCM control relay | 3 | PCM |
| 2 | TCV | | |

- At low engine speeds the PCM controls the TCV with a large duty cycle, so that the pressure on the high-pressure side of the timer piston decreases. Due to this the spring force overcomes the hydraulic force and the piston moves away from the spring. Thus the roller ring rotates into the turning direction of the cam plate, retarding the injection timing.
- At high engine speeds the PCM controls the TCV with a small duty cycle, so that the pressure on the high-pressure side of the timer piston increases. Due to this the hydraulic force overcomes the spring force and the piston moves into the direction of the spring. Thus the roller ring rotates against the turning direction of the cam plate, advancing the injection timing.

NOTE: When the TCV fails the solenoid valve adopts in the closed position, advancing the injection timing. This can be recognized by the increased engine noise at idle (Diesel knocking).

- The PCM controls the TCV by a duty signal 0 V/12V.

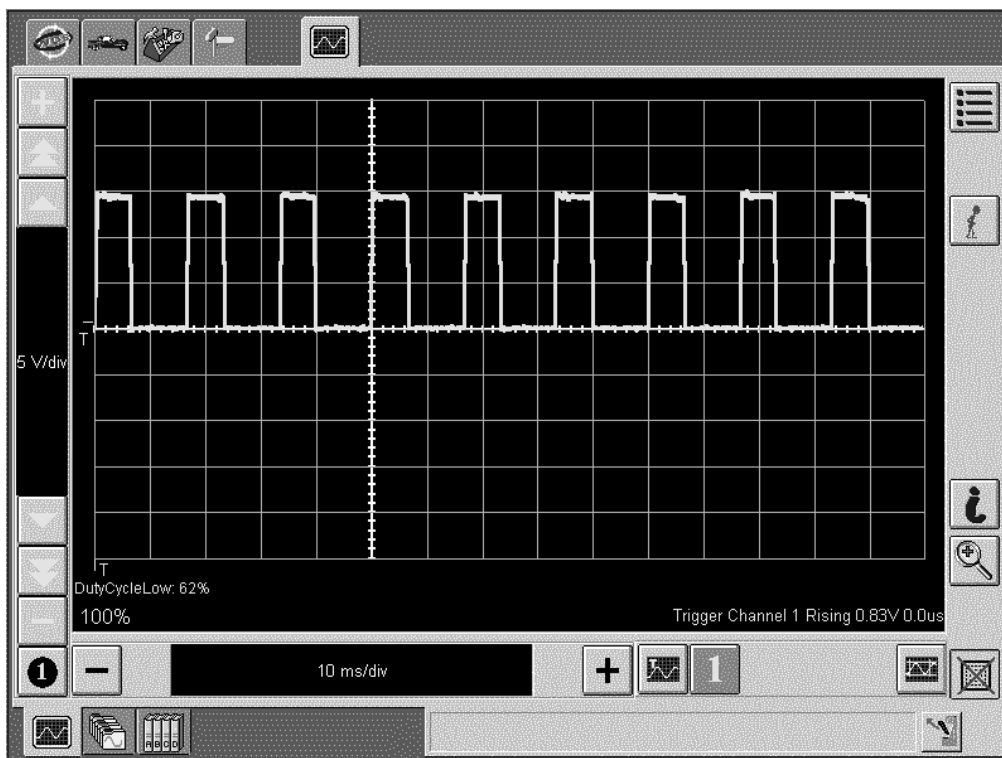

TCV Signal

Timer Position Sensor

- The **TPS (Timer Position Sensor)** detects the position of the roller ring, giving a feedback about the actual injection timing to the PCM. The sensor is located at the timer device and consists of an iron core and two coils.
- The PCM supplies the coils with a constant alternating current, generating a magnetic field. The iron core is joint to the timer piston and moves in the coils, when the piston moves. Due to the length of the iron core the magnetic field and hence the voltage of the measuring coil changes.
- In the reference coil the magnetic field and hence the voltage is constant. The PCM calculates an accurate position of the timer piston by comparing the voltage values of both coils and thereby detects the position of the roller ring.

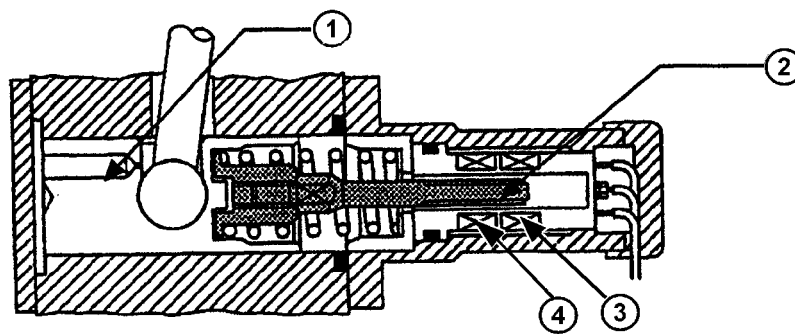

M RF DF6-10

1 Timer piston
2 Iron core

3 Measuring coil
4 Reference coil

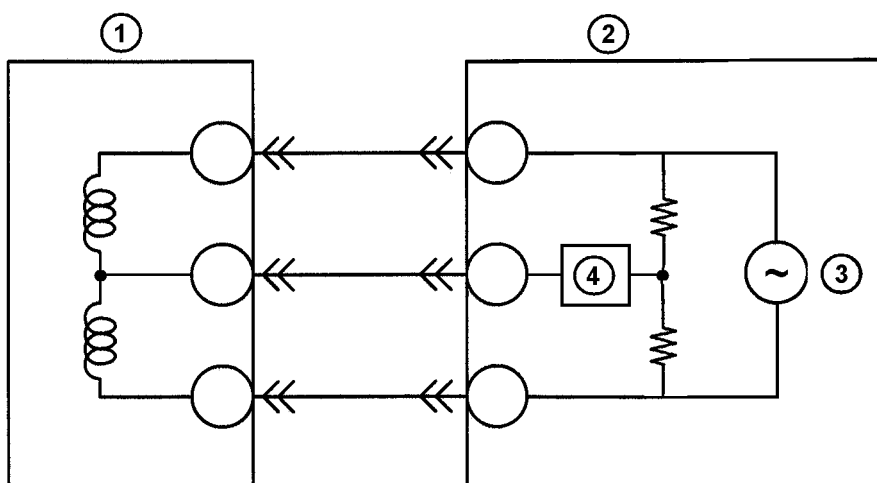

M 1724 F2-111

1 TPS
2 PCM

3 Voltage supply
4 Voltage detection circuit

Pump Speed Sensor

- The pump speed sensor is mounted on the injection pump housing and detects the position of the pump's drive shaft. The inductive sensor consists of a permanent magnet and a coil, which scan a rotor with five teeth. The rotor is connected to the drive shaft, turning with half of the engine speed.

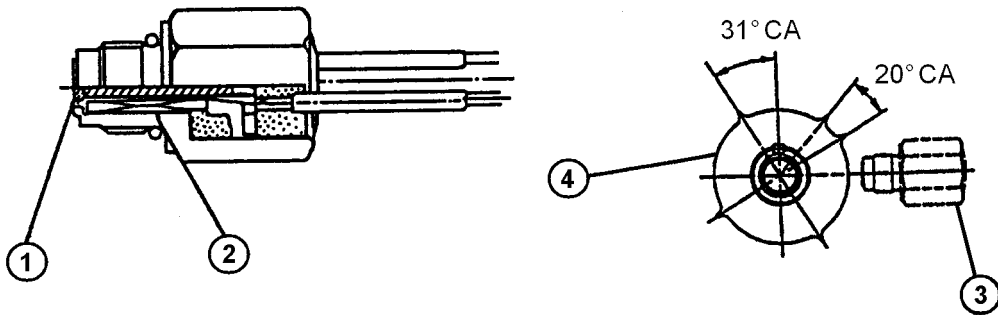

RF TCI S23 u

- | | | | |
|---|--------|---|-------------------|
| 1 | Magnet | 3 | Pump speed sensor |
| 2 | Coil | 4 | Toothed rotor |

- When the rotor passes the sensor, an alternating voltage is induced in the coil and input to the PCM. The level of the alternating voltage depends on the distance between sensor and rotor as well as on the speed of the drive shaft, i.e. the amplitude rises with decreasing distance and increasing speed. The signal of the pump speed sensor is used for calculation of the engine speed and for identification of cylinder no.1.

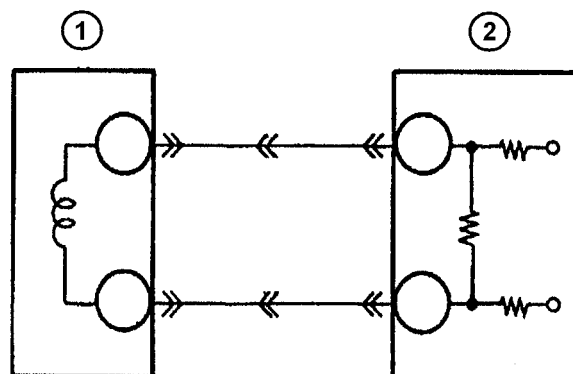

M EGI S 169 m2_Bild

- | | | | |
|---|-------------------|---|-----|
| 1 | Pump speed sensor | 2 | PCM |
|---|-------------------|---|-----|

- The pump speed sensor supplies the PCM with an alternating voltage between 1.5...4 V (peak to peak).

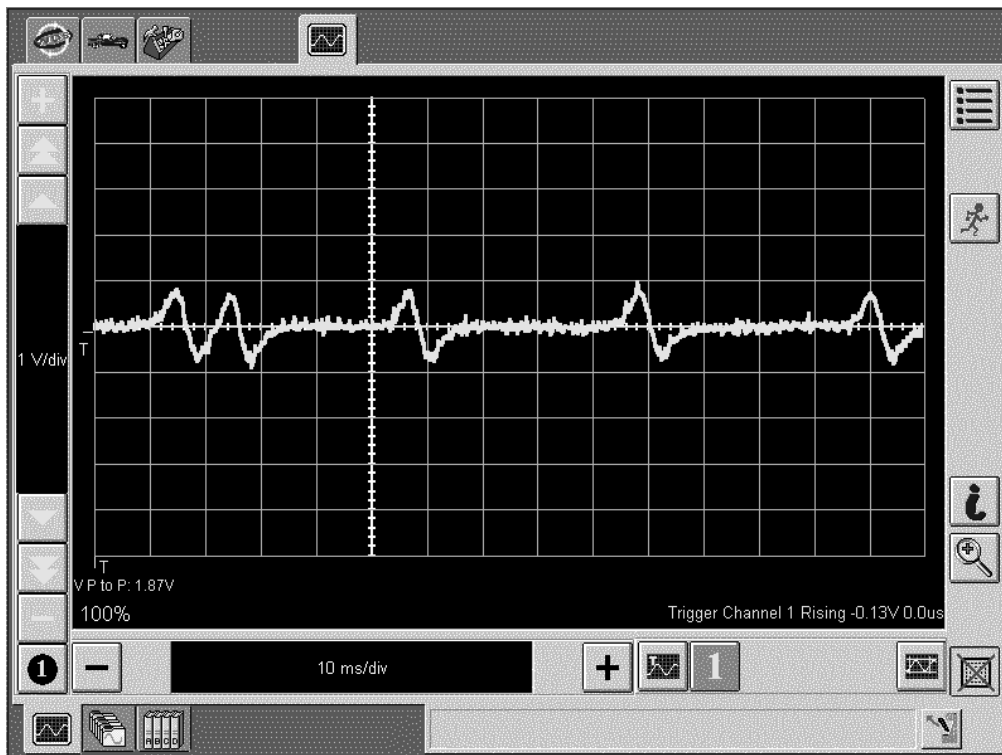

RPM Signal

Diagnostics

- The components of the injection timing control can be checked as following:
 - Monitoring/Activating the TCV via the PID **TCV** (Per)
 - Checking the voltage signal of the TCV
 - Checking the resistance of the TCV
 - Checking the voltage signal of the TPS
 - Checking the resistance of the TPS
 - Monitoring the pump speed sensor via the PID **RPM** (Rpm)
 - Checking the voltage signal of the pump speed sensor
 - Checking the resistance of the pump speed sensor

Emission System

Parts Location

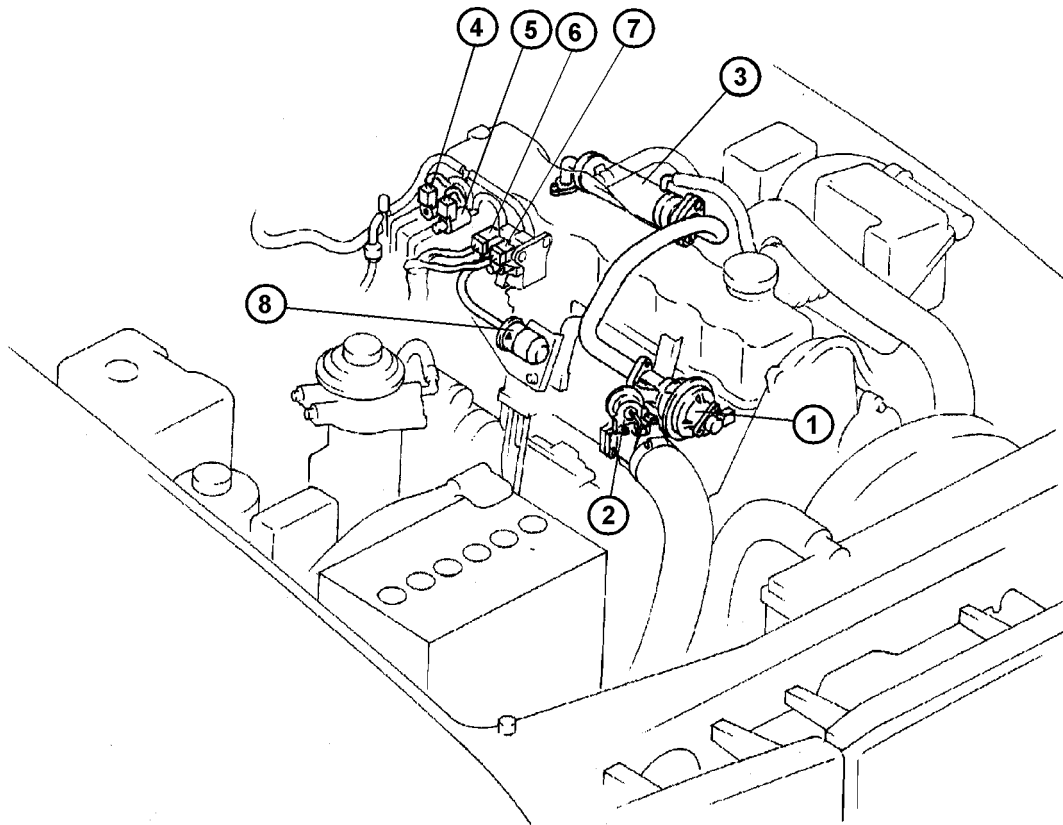

M 1724 F2-17

- | | | | |
|---|-----------------------------------|---|---------------------------------|
| 1 | EGR valve | 5 | EGR ventilation solenoid valve |
| 2 | Intake shutter valve (only WLT-3) | 6 | EGR control solenoid valve |
| 3 | EGR cooler | 7 | ISV solenoid valve (only WLT-3) |
| 4 | EGR vacuum solenoid valve | 8 | Air filter |

System Overview

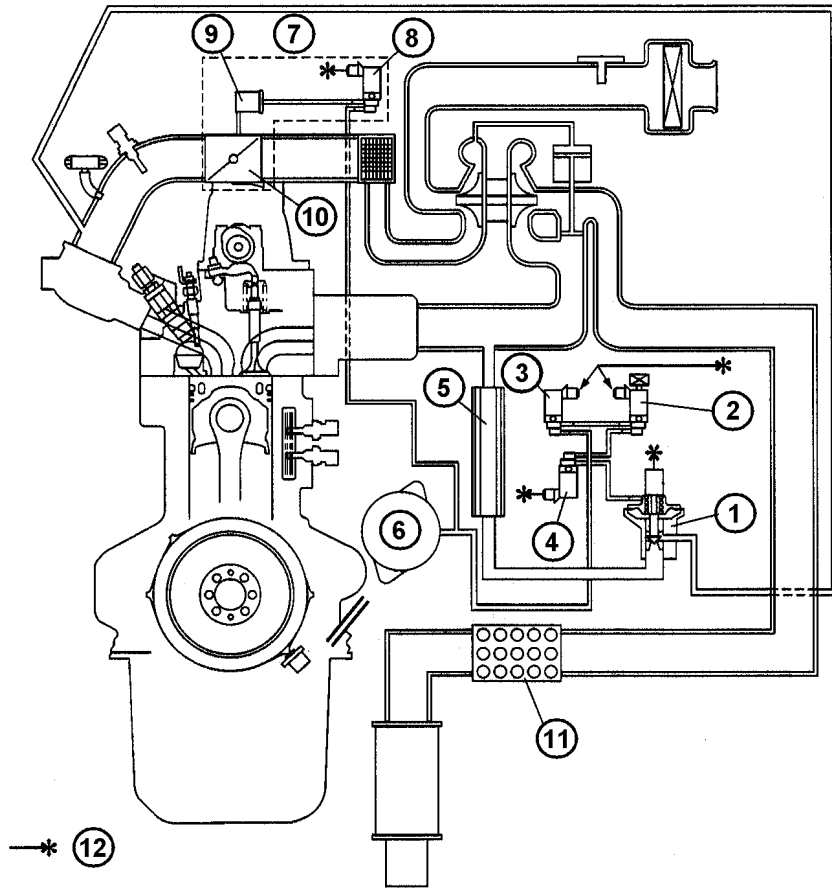

M 1724 F2-18

- | | | | |
|---|--------------------------------|----|-------------------------------|
| 1 | EGR valve | 7 | only WLT-3 |
| 2 | EGR ventilation solenoid valve | 8 | ISV solenoid valve |
| 3 | EGR vacuum solenoid valve | 9 | ISV vacuum actuator |
| 4 | EGR control solenoid valve | 10 | ISV |
| 5 | EGR cooler | 11 | Oxidation catalytic converter |
| 6 | Vacuum pump | 12 | To PCM |

Exhaust System

Features

- The exhaust system of the vehicles with WL-3/WLT-3 engine has the following features:
 - Oxidation catalytic converter (similar to that of the Denso common rail system)

Exhaust Gas Recirculation System

Features

- The exhaust gas recirculation system of the vehicles with WL-3/WLT-3 engine has the following features:
 - EGR valve with vacuum actuator and position sensor (similar to that of the Denso common rail system)
 - EGR vacuum, EGR ventilation and EGR control solenoid valve (similar to those of the Denso common rail system)
 - EGR cooler (similar to that of the Denso common rail system)
 - Two-step intake shutter valve with vacuum actuator has been introduced for vehicles with WLT-3 engine.
 - ISV solenoid valve for vehicles with WLT-3 engine

Intake Shutter Valve

- The B2500 UN with WLT-3 engine features an ISV, which is driven by a vacuum actuator with one diaphragm (two-step type). The position of the ISV is controlled by the PCM, which activates the ISV solenoid valve via an ON/OFF signal.

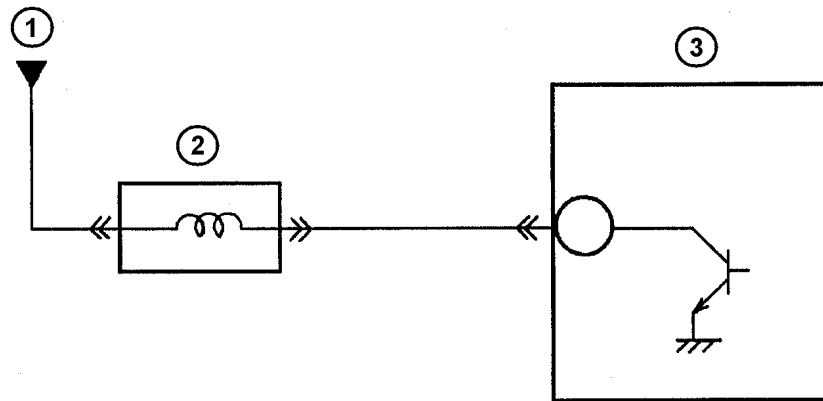

E51178

- 1 From PCM control relay
- 2 ISV solenoid valve

3 PCM

- When the required EGR rate is high the PCM energizes the ISV solenoid valve, so that vacuum is applied to the vacuum actuator. Due to this the ISV closes halfway, reducing the cross-section of the intake pipe. Thus a vacuum is generated in the intake manifold and a large amount of exhaust gas can be recirculated.
- When the required EGR rate is low the PCM de-energizes the ISV solenoid valve, so that atmosphere pressure is applied to the vacuum actuator. Due to this the ISV opens, making the complete cross-section of the intake pipe available. Thus atmosphere or boost pressure is generated in the intake manifold (depending on the operating conditions) and only a small amount of exhaust gas can be recirculated.

NOTE: If the ISV system fails, the ISV adopts in the open position in which no vacuum is produced.

Diagnostics

- The EGR system can be checked as following:
 - Monitoring the actual EGR rate via the PID **MAF** (Volt)
 - Monitoring/Activating the EGR solenoid valves (vacuum/ventilation/control) via the PIDs **EGRV#**/ **EGRA#**/**EGRV2#** (Per/Mode)
 - Checking the voltage signal at the EGR solenoid valves (vacuum/ventilation/control)
 - Checking the EGR valve for sticking (similar to the Denso common rail system)
 - Monitoring the EGRVP sensor via the PID **EGRVP** (Volt)
 - Checking the voltage of the EGRVP sensor
 - Checking the resistance of the EGRVP sensor
 - Monitoring / Activating the ISV via the PID **IASV#** (Mode)
 - Checking the voltage at the ISV solenoid valve
 - Checking the function of the ISV

Checking the function of the ISV

- Connect a hand-operated vacuum pump to the ISV actuator and apply vacuum. Check, whether the adjusting linkage moves easily, and returns to the parked position when the system is vented.

Control System

Parts Location

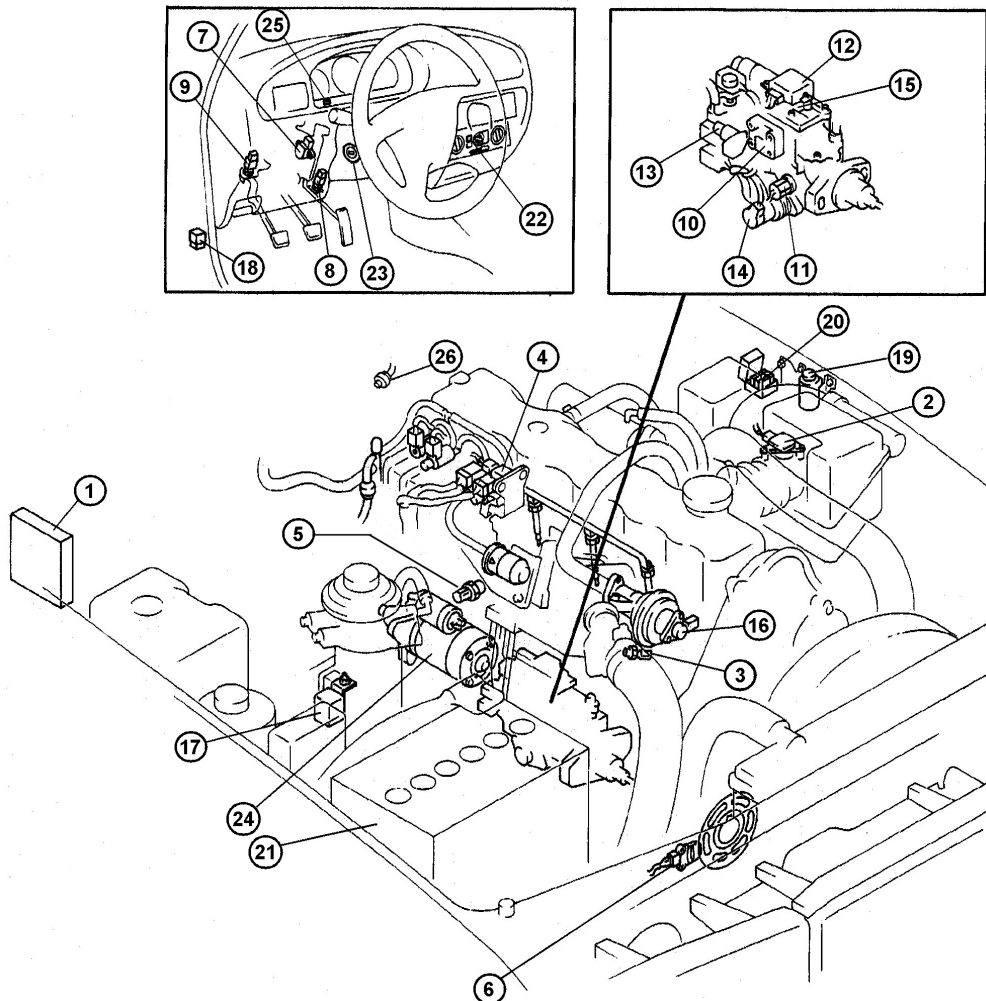

M 1724 F2-22

- | | | | |
|----|--|----|------------------------------|
| 1 | PCM (incl. barometric pressure sensor) | 14 | TPS |
| 2 | MAF/IAT sensor | 15 | CSP sensor |
| 3 | IAT sensor | 16 | EGRVP sensor |
| 4 | MAP sensor | 17 | Glow plug relay |
| 5 | Engine coolant temperature sensor | 18 | PCM control relay |
| 6 | Crankshaft position sensor | 19 | A/C relay |
| 7 | Accelerator pedal position sensor | 20 | Data link connector |
| 8 | Idle switch | 21 | Battery |
| 9 | Clutch pedal position switch | 22 | A/C switch |
| 10 | FLT sensor | 23 | Engine switch |
| 11 | Pump speed sensor | 24 | Starter |
| 12 | Injection pump PROM | 25 | Glow indicator light |
| 13 | TCV | 26 | Park neutral position switch |

Block Diagram

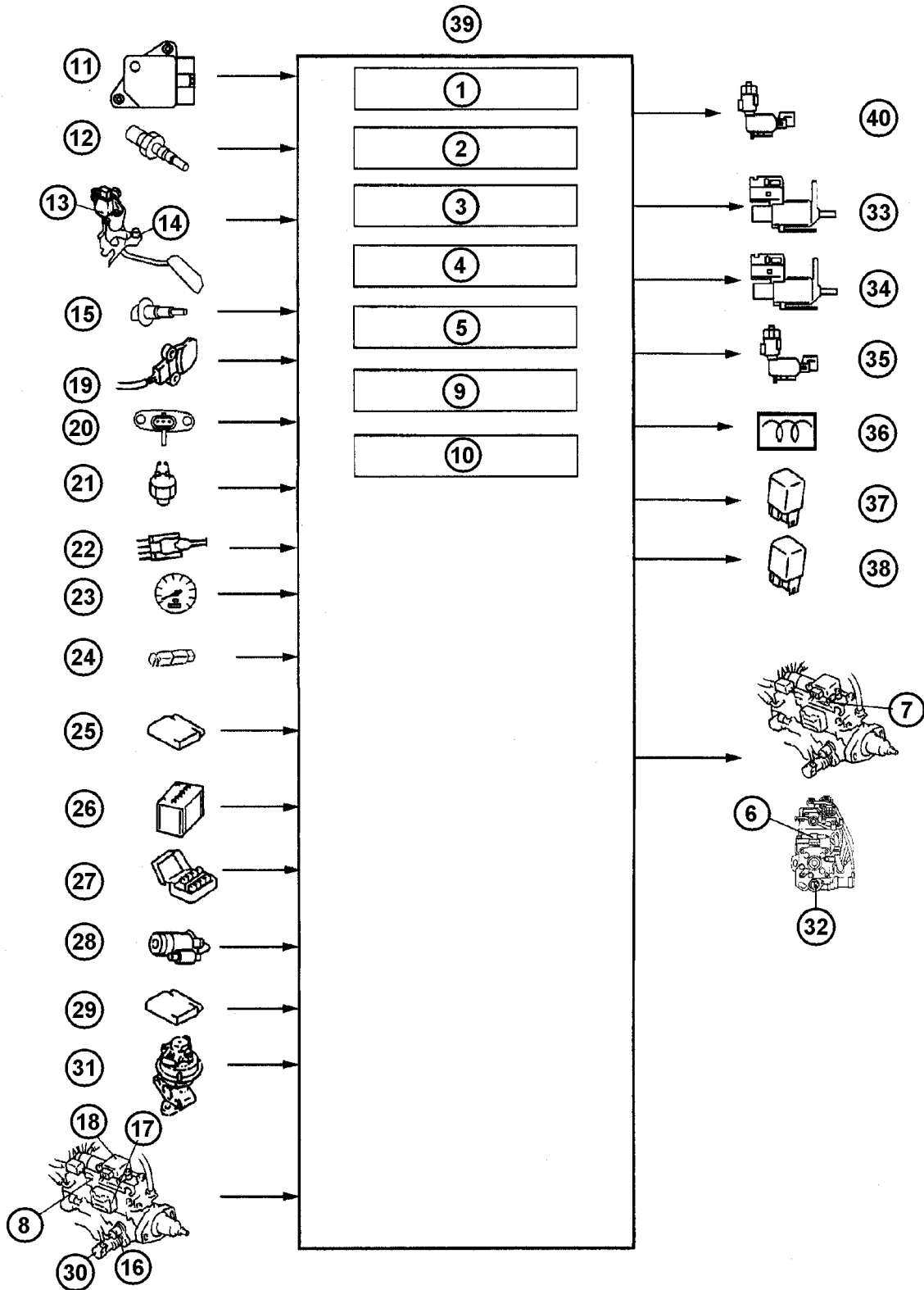

M 1724 F2-24

1	Injection amount control	21	Park neutral position switch
2	Injection timing control	22	Clutch pedal position switch
3	Idle speed control	23	Vehicle speed sensor
4	Glow control	24	A/C switch (with A/C)
5	EGR control	25	Immobilizer module
6	FSOV	26	Battery
7	Electronic governor	27	Data link connector
8	CSP sensor	28	Starter (starter signal)
9	A/C control (if equipped)	29	Barometric pressure sensor (in PCM)
10	Immobilizer system	30	TPS
11	MAF/IAT sensor	31	EGRVP sensor
12	Engine coolant temperature sensor	32	TCV
13	Accelerator pedal position sensor	33	EGR vacuum solenoid valve
14	Idle switch	34	EGR ventilation solenoid valve
15	IAT sensor	35	EGR control solenoid valve
16	Pump speed sensor	36	Glow indicator light
17	FLT sensor	37	Glow plug relay
18	Injection pump PROM	38	A/C relay (with A/C)
19	Crankshaft position sensor	39	PCM
20	MAP sensor	40	ISV solenoid valve (only WLT-3)

Relationship Chart

x: Applicable

Device		Control Item					
		Injection amount control	Injection timing control	Glow control	EGR control	A/C control	Immobilizer system
Input	Engine coolant temperature sensor	X	X	X	X	X	
	Accelerator pedal position sensor	X	X		X	X	
	Idle switch	X			X		
	MAF/IAT sensor	X			X		
	IAT sensor No.2	X					
	Pump speed sensor	X	X		X	X	
	FLT sensor	X					
	Injection pump PROM	X					
	Crankshaft position sensor	X	X		X		
	MAP sensor	X					
	Park / Neutral position switch	X	X		X	X	
	Clutch pedal position switch	X	X		X	X	
	Vehicle speed sensor	X		X		X	
	EGRVP sensor				X		
	Barometric pressure sensor (in PCM)	X	X				
	Immobilizer module						X
	Battery voltage			X			
	Starter signal	X	X			X	
	CSP sensor	X					
	TPS		X				
A/C switch	X						
Output	Electronic governor	X					
	TCV		X				
	EGR solenoid valve (vacuum/ventilation/control)				X		
	FSOV	X					X
	Glow indicator light			X			
	Glow plug relay			X			
	A/C relay					X	
	ISV solenoid valve (only WLT-3)				X		

Zexel IP Rel

Powertrain Control Module

Features

- The powertrain control module of the vehicles with WL-3/WLT-3 engine has the following features:
 - Read-only memory (similar to that of the Denso common rail system)
 - Random-access memory with keep-alive power supply (similar to that of the Denso common rail system)

Sensors

Features

- The sensors of the vehicles with WL-3/WLT-3 engine have the following features:
 - Hall-type crankshaft position sensor
 - Potentiometer-type accelerator pedal position sensor (similar to that of the Denso common rail system)
 - Idle switch (similar to that of the Denso common rail system)
 - Engine coolant temperature sensor (similar to that of the Denso common rail system)
 - Barometric pressure sensor integrated in PCM (similar to that of the Denso common rail system)
 - Clutch pedal position switch and park/neutral position switch with joint PCM terminal for both sensors

Crankshaft Position Sensor

- The B2500 UN with WL-3/WLT-3 engine features a hall-type CKP sensor (also termed as TDC sensor). The sensor consists of a hall element and a magnet, which scan a rotor with four teeth.

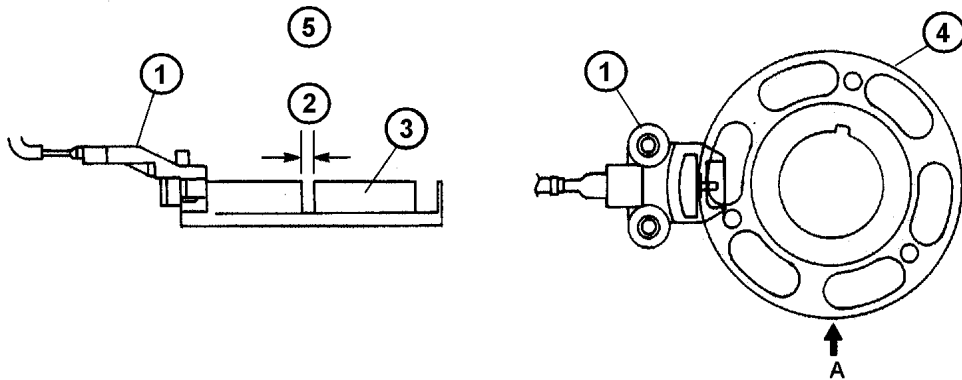

M 1724 F2-32

- | | | | |
|---|------------|---|---------------|
| 1 | CKP sensor | 4 | Toothed rotor |
| 2 | Tooth gap | 5 | View A |
| 3 | Tooth | | |

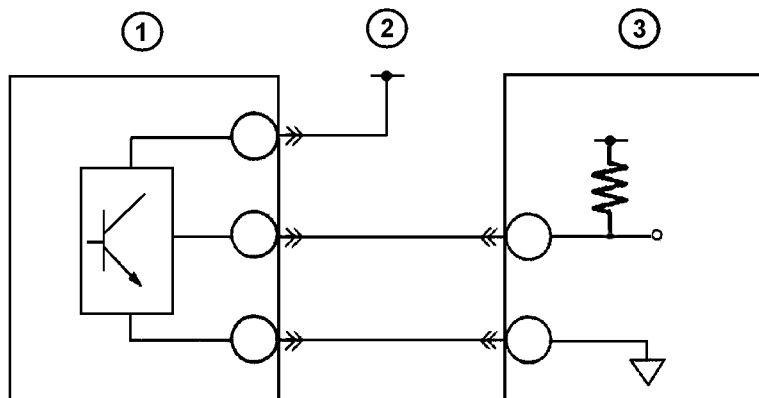

M 1724 F2-98-m

- | | | | |
|---|------------------------|---|-----|
| 1 | CKP sensor | 3 | PCM |
| 2 | From PCM control relay | | |

- The CKP sensor supplies the PCM with a digital voltage signal 0 V/5 V.

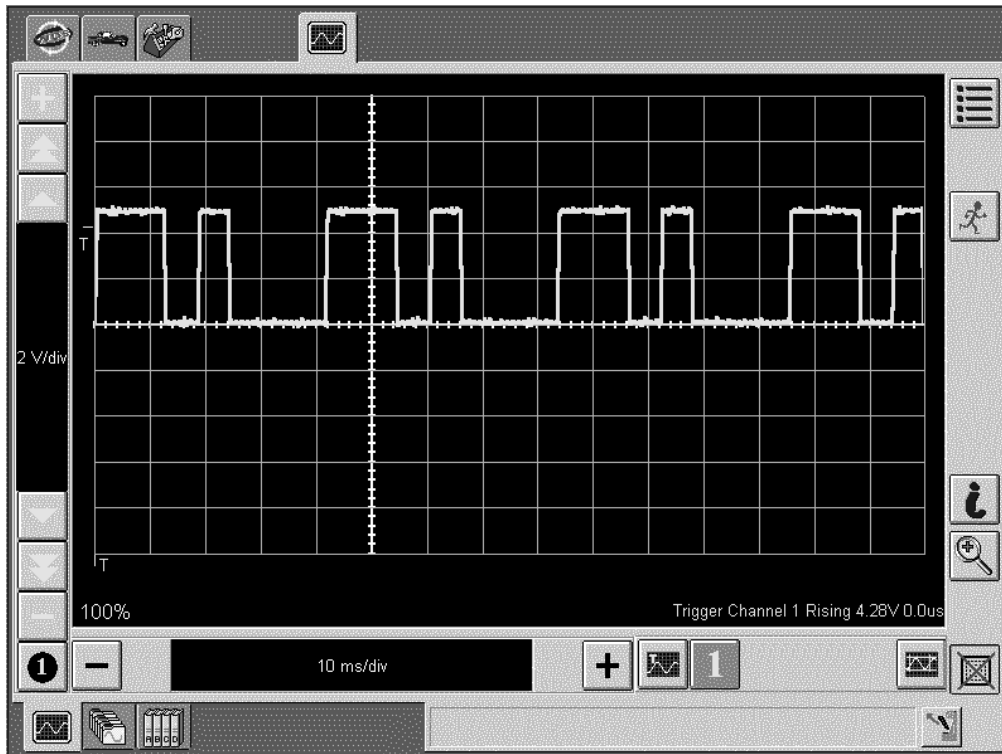

CKP Signal

Diagnostics

- The CKP sensor can be checked as following:
 - Checking the voltage signal
 - Checking the voltage supply

Actuators

Features

- The actuators of the vehicles with WL-3/WLT-3 engine have the following features:
 - Glow plug relay without feedback to the PCM has been introduced.
 - A/C compressor (similar to that of the Denso common rail system)
 - Immobilizer system with separate immobilizer module

Immobilizer System

- The B2500 UN with WL-3/WLT-3 engine is equipped with a separate immobilizer module. The PCM deactivates the electronic governor and the FSOV, when the vehicle is started with an invalid key. As the immobilizer system disables the starter as well, the engine doesn't even crank.

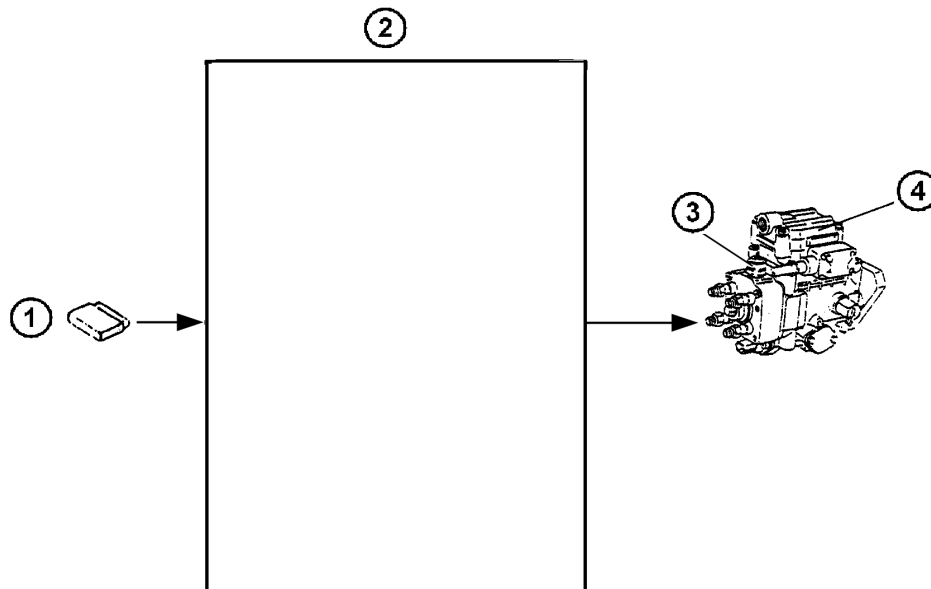

M 1614 F2-47

1 Immobilizer module
2 PCM

3 FSOV
4 Electronic governor

NOTE: For diagnosis on the immobilizer system refer to the workshop manual (section T – Immobilizer System).

Denso Injection Pump System

Denso Injection Pump System

Features

- The 323 BJ, 626 GF/GW and Premacy CP with RF-T engine are equipped with the Denso injection pump system ECD-V5. This system has the following features:
 - Axial piston-type injection pump with spill valve
 - Two-spring injectors
 - Injection pump pressure of max. 100 MPa

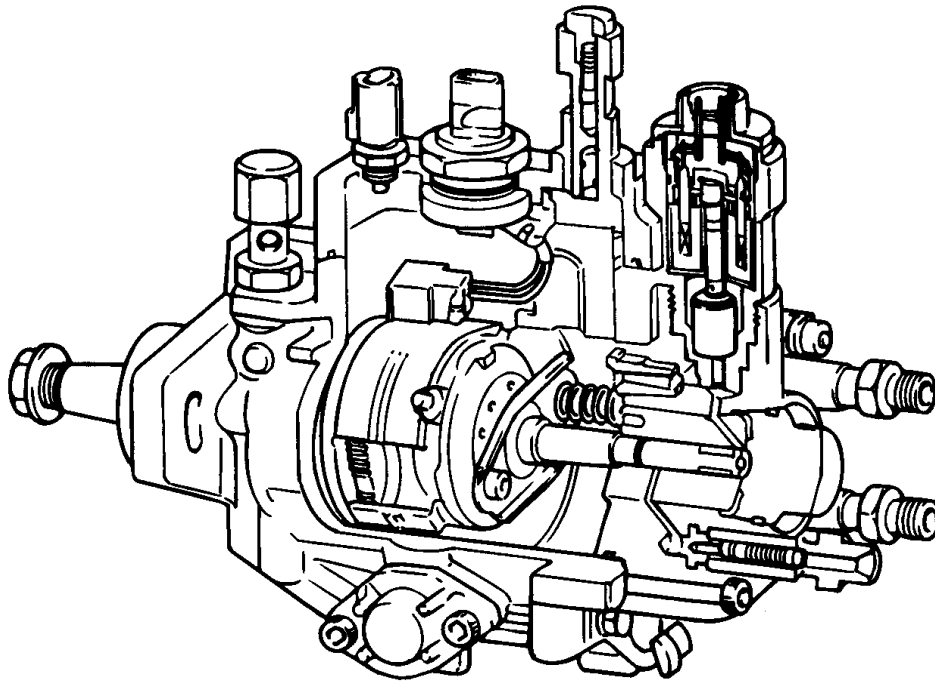

Denso P

NOTE: Some of the components of the Denso injection pump system are very similar in design and operation to those of the common rail systems or to the Zexel injection pump system. Therefore this section only describes the components which are new or operate in a different way to those of the common rail systems or of the Zexel injection pump system.

Intake-air System

Features

- The intake-air system of the Denso injection pump system has the following features:
 - Hot wire-type mass air flow sensor with integrated intake air temperature sensor for Euro 3 vehicles (similar to that of the Denso common rail system)
 - Turbocharger with variable geometry turbine for Euro 3 vehicles (similar to that of the Denso common rail system)
 - Charge-air cooler (similar to that of the Denso common rail system)
 - Manifold absolute pressure sensor (similar to that of the Denso common rail system)
 - Intake air temperature sensor (similar to that of the Denso common rail system)
 - Variable swirl control valves for Euro 3 vehicles (similar to those of the Denso common rail system)

Parts Location

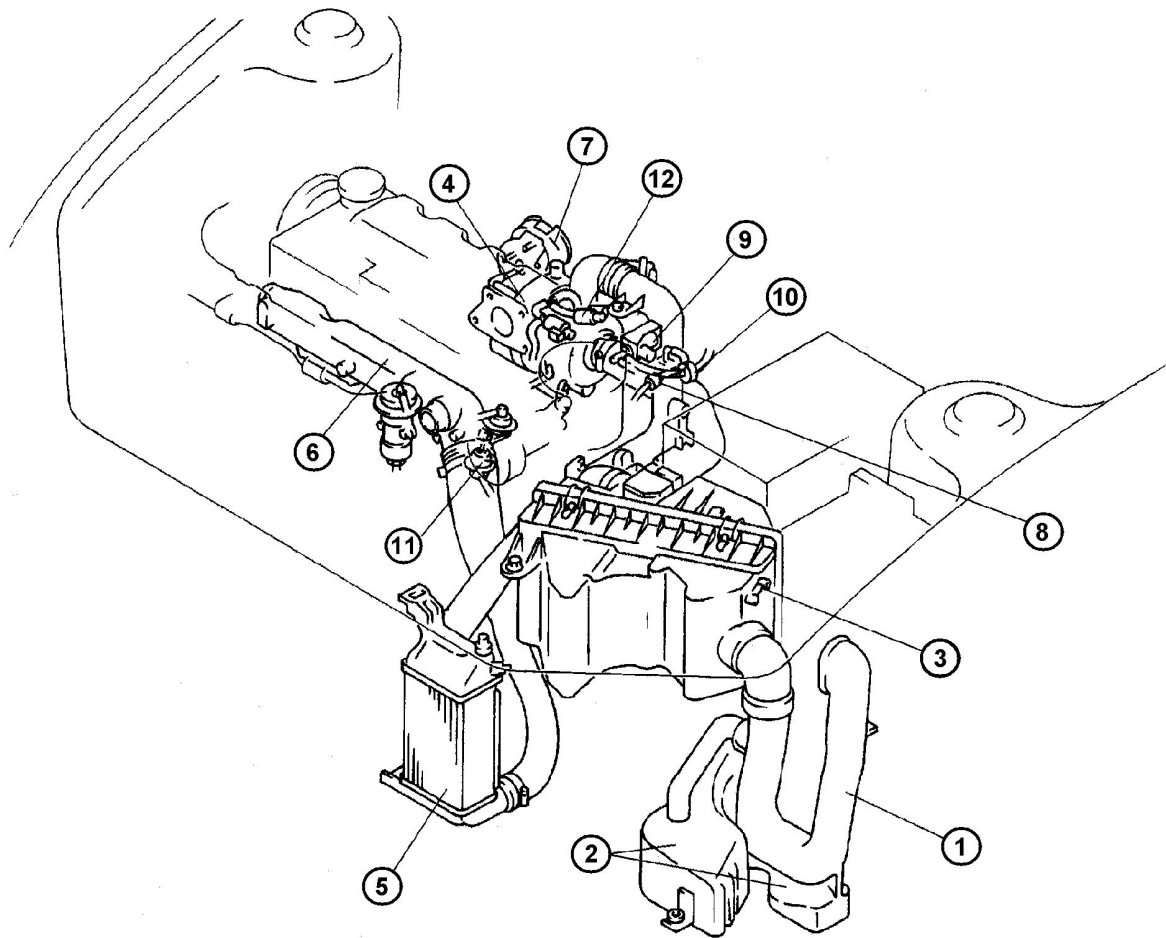

M 1704 F5-7

- | | | | |
|---|-------------------|----|---------------------|
| 1 | Fresh-air duct | 7 | VBC vacuum actuator |
| 2 | Resonance chamber | 8 | VBC check valve |
| 3 | Air cleaner | 9 | VBC solenoid valve |
| 4 | Turbocharger | 10 | VBC vacuum damper |
| 5 | Charge-air cooler | 11 | VSC vacuum actuator |
| 6 | Intake manifold | 12 | VSC solenoid valve |

System Overview

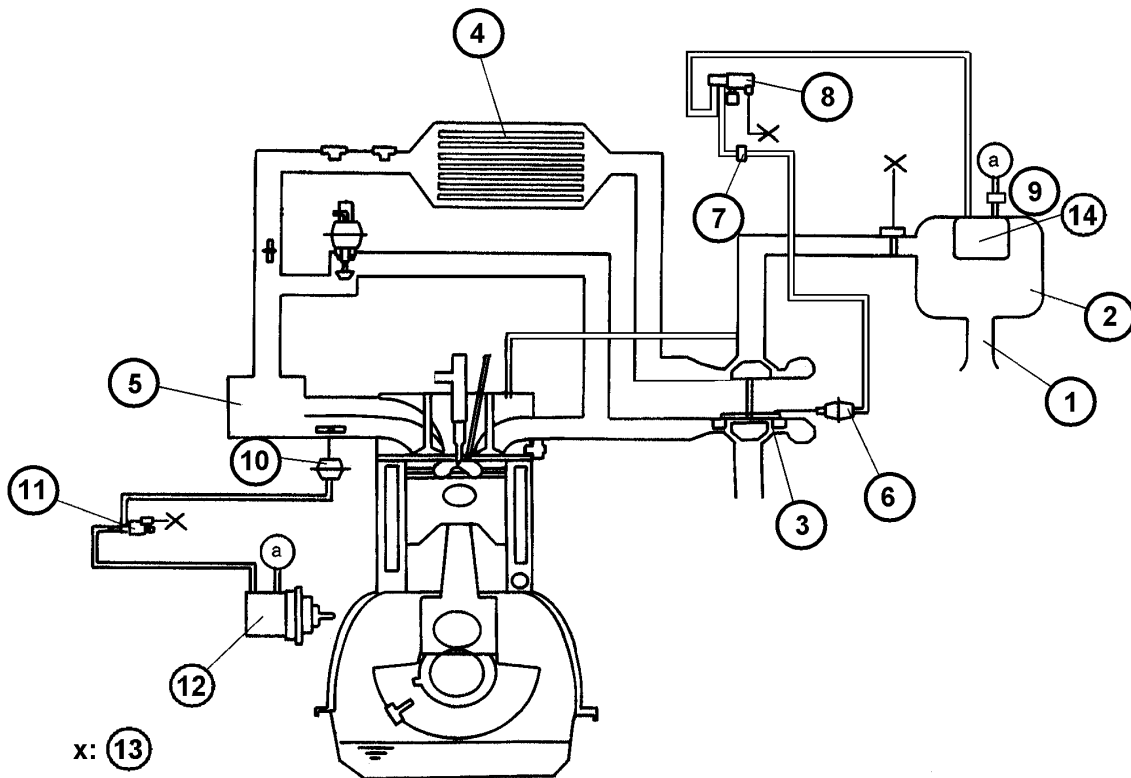

M 1688 F2-12

- | | | | |
|---|---------------------|----|---------------------|
| 1 | Fresh-air duct | 8 | VBC solenoid valve |
| 2 | Air cleaner | 9 | VBC check valve |
| 3 | Turbocharger | 10 | VSC vacuum actuator |
| 4 | Charge-air cooler | 11 | VSC solenoid valve |
| 5 | Intake manifold | 12 | Vacuum pump |
| 6 | VBC vacuum actuator | 13 | To PCM |
| 7 | VBC vacuum damper | 14 | Vacuum chamber |

Fuel System

Parts Location

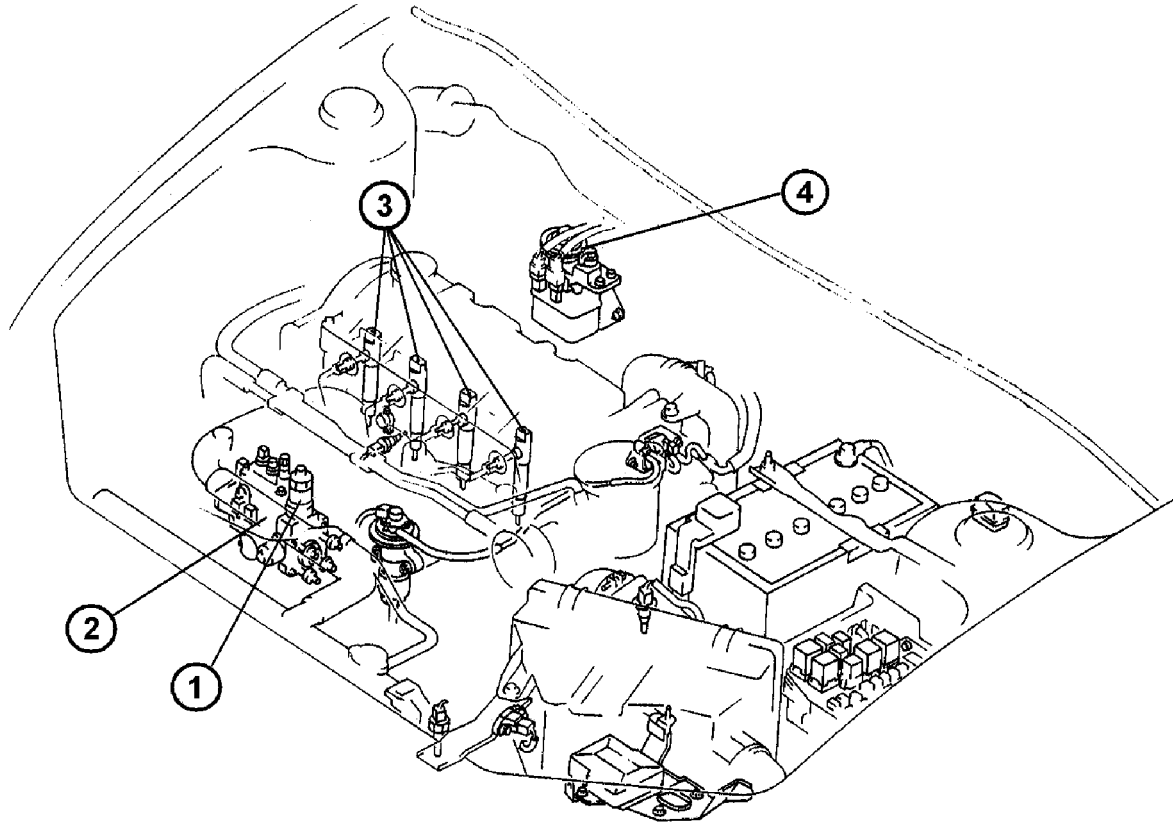

M 1633 F5-10

1 Spill valve
2 Injection pump

3 Injector
4 Fuel filter

System Overview

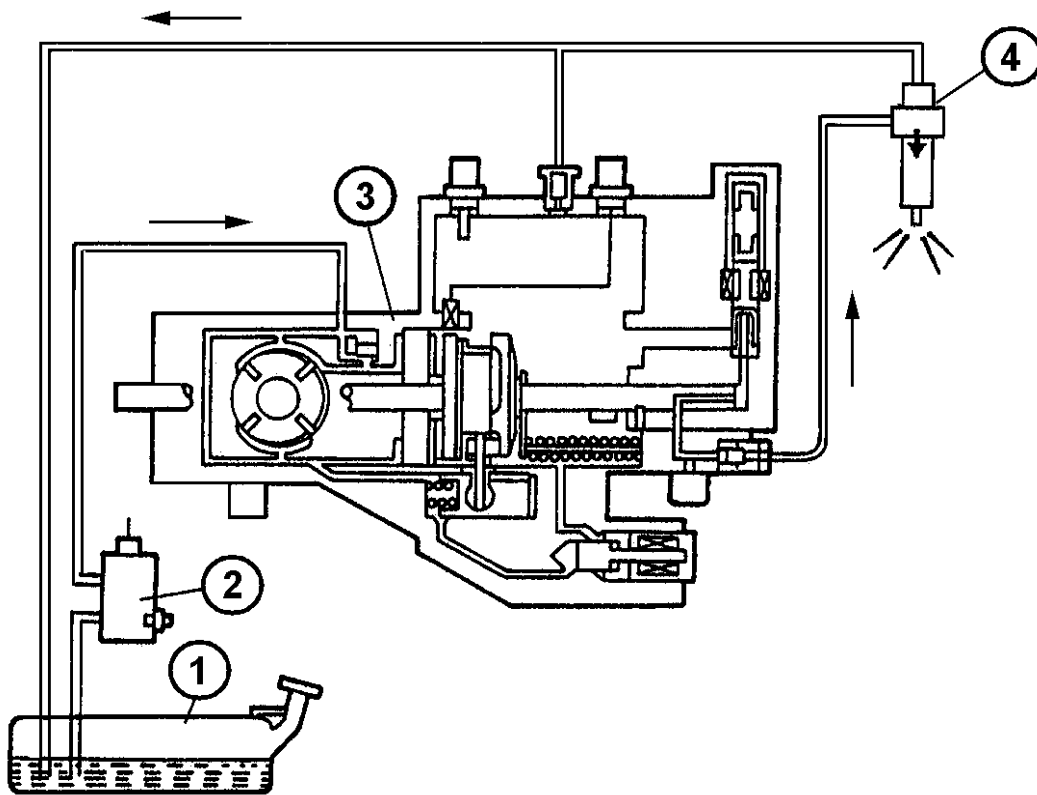

M 3336 F2-10u

- 1 Fuel tank
- 2 Fuel filter

- 3 Injection pump
- 4 Injector

Injection Pump

- The ECD-V5 injection pump system features an axial piston-type injection pump manufactured by Denso.

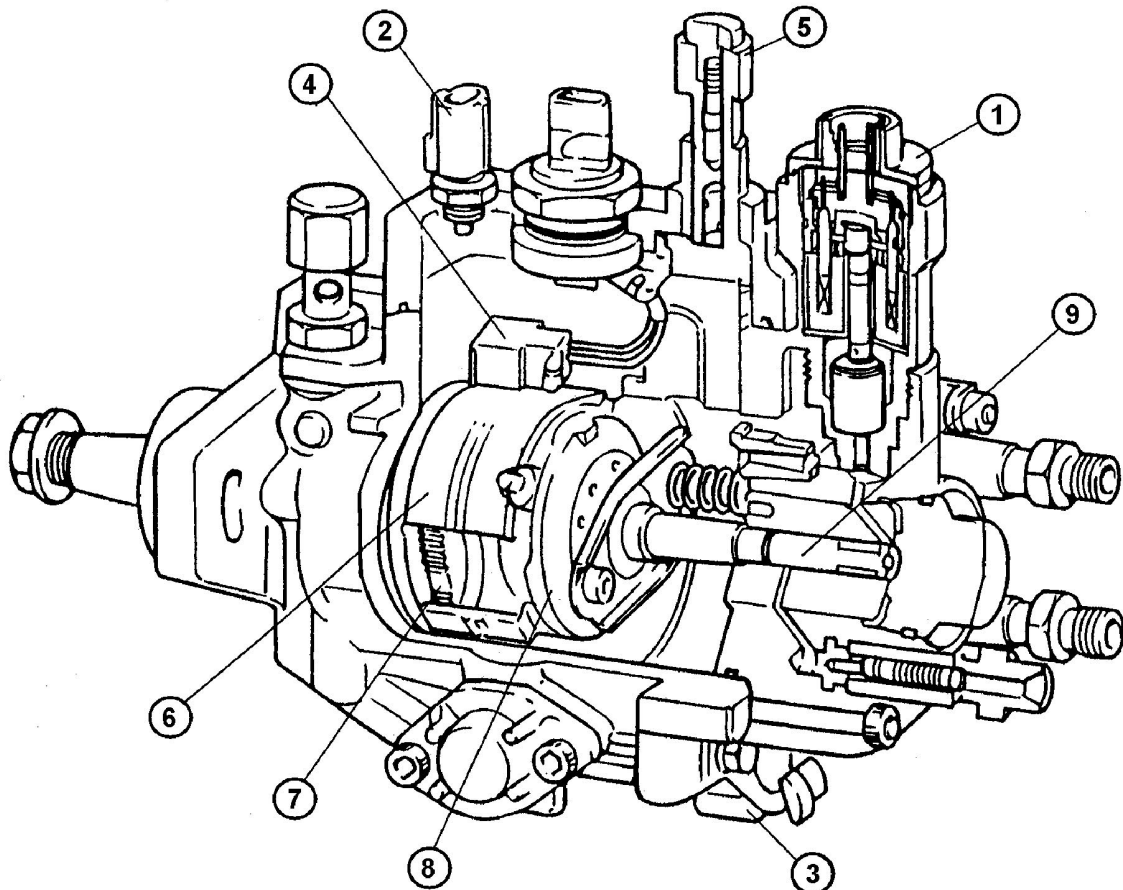

M 1614 F2-12

- | | | | |
|---|-------------------------|---|---------------------|
| 1 | Spill valve | 6 | Roller ring |
| 2 | FLT sensor | 7 | Toothed rotor |
| 3 | TCV | 8 | Cam plate |
| 4 | Pump speed sensor | 9 | Distributor plunger |
| 5 | Overflow throttle valve | | |

Low-pressure System

Features

- The low-pressure system of the vehicles with RF-T engine has the following features:
 - Fuel filter with priming pump and water level sensor (similar to that of the Denso common rail system)
 - Fuel warmer controlled by a vacuum switch (similar to that of the Denso common rail system)
 - Vane-type feed pump (similar to that of the Siemens common rail system)
 - Pressure control valve (similar to that of the Denso common rail system)
 - Overflow throttle valve (similar to that of the Denso common rail system)

High-pressure System

Features

- The high-pressure system of the vehicles with RF-T engine has the following features:
 - Axial piston-type distributor pump with spill valve has been introduced
 - Pressure valves (similar to those of the Zexel injection pump system)
 - Two-spring injectors have been introduced.

Axial-piston Distributor Pump

- Vehicles with RF-T engine feature an axial-piston distributor pump with spill valve. The valve is located in an additional passage, which connects the high-pressure chamber to the pump chamber, and opens or closes this passage.

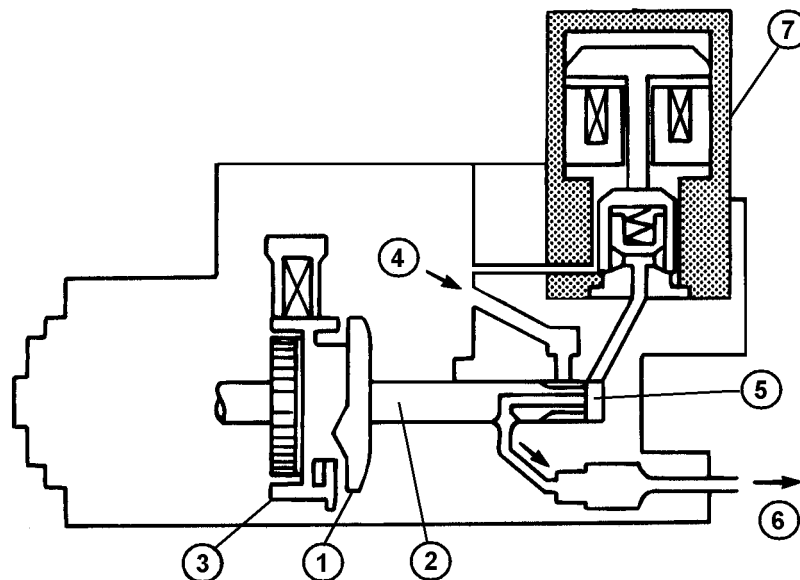

DS 16 QT0285E

- | | | | |
|---|---------------------|---|-----------------------|
| 1 | Cam plate | 5 | High-pressure chamber |
| 2 | Distributor plunger | 6 | To injector |
| 3 | Roller ring | 7 | Spill valve |
| 4 | From pump chamber | | |

- As the distributor plunger moves from TDC to BDC, the spill valve opens the additional passage and fuel flows through the open inlet passage into the high-pressure chamber (= filling phase).

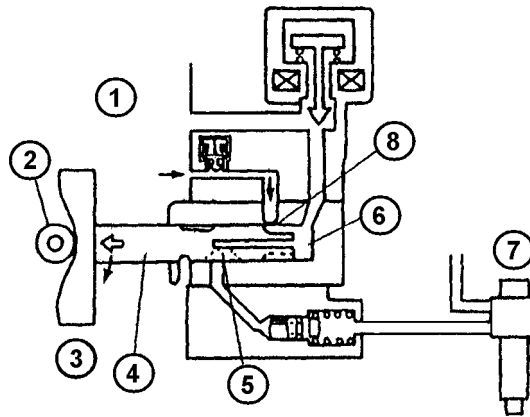

M 1614 F2-13 o li

- | | | | |
|---|---------------------|---|-----------------------|
| 1 | Pump chamber | 5 | Distribution slot |
| 2 | Roller ring | 6 | High-pressure chamber |
| 3 | Cam plate | 7 | Injector |
| 4 | Distributor plunger | 8 | Intake port |

- At BDC the plungers rotating movement then closes the inlet passage and the distributor slot opens a certain outlet port. When the plunger moves from BDC to TDC (= working stroke), the spill valve closes the additional passage and fuel is compressed in the high-pressure chamber (= high-pressure phase). As the pressure rises in the high-pressure chamber and in the outlet port passage, the pressure valve in question opens and fuel is forced through the high-pressure line to the injector.

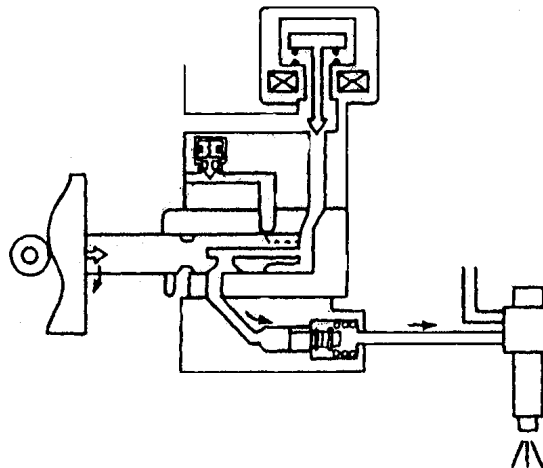

M 1614 F2-13 o re

- The working stroke is completed as soon as the spill valve opens the additional passage, returning the surplus fuel to the pump chamber (= end of high-pressure phase). As the pressure in the high-pressure chamber decreases, the pressure valve closes the high-pressure line and no more fuel is delivered to the injector.

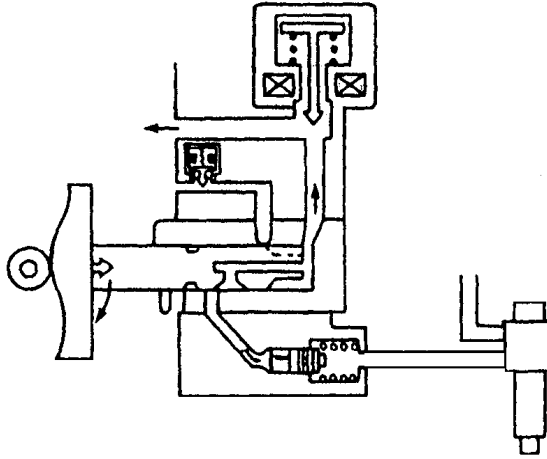

M 1614 F2-13 u li

Injectors

- Vehicles with RF-T engine feature two-spring injectors, which consist of nozzle body with nozzle needle, pressure pin, two springs and stop sleeve.
- The injectors are equipped with a hole-type nozzle with six spray holes, each with a diameter of 0.18 mm (only Euro 3 vehicles).

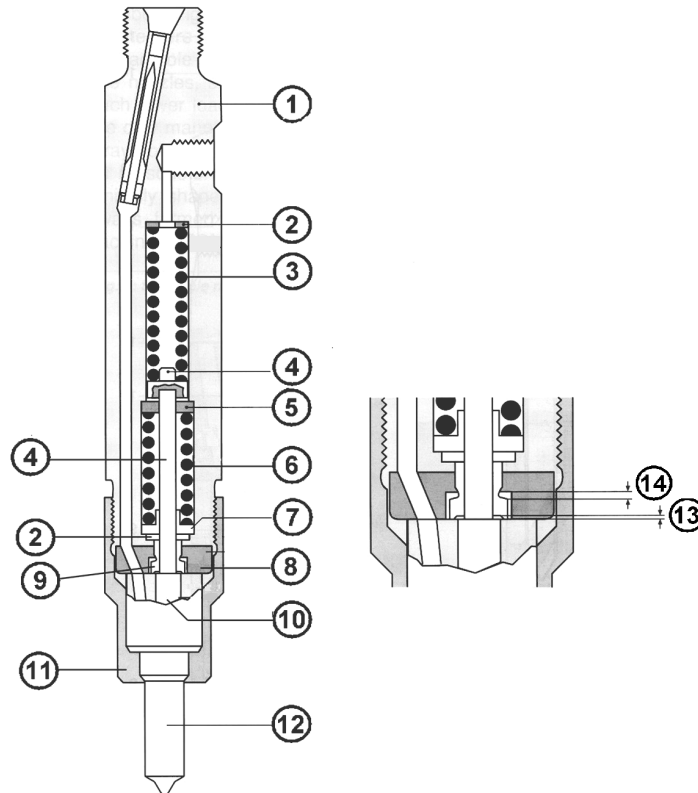

B S48 F7

- | | | | |
|---|--------------------|----|----------------------|
| 1 | Nozzle body | 8 | Intermediate element |
| 2 | Adjustment shim | 9 | Stop sleeve |
| 3 | Nozzle spring no.1 | 10 | Nozzle needle |
| 4 | Pressure pin | 11 | Nozzle retaining nut |
| 5 | Guide element | 12 | Nozzle |
| 6 | Nozzle spring no.2 | 13 | Initial stroke |
| 7 | Spring seat | 14 | Main stroke |

- The two-spring injector injects the fuel in two steps into the combustion chamber. It features two springs with different spring rates, which are located one behind the other. During the injection process the nozzle needle is lifted against the force of spring no.1 (low spring rate), until it reaches the stop sleeve. Due to this the nozzle needle opens by the initial stroke, so that only a small amount of fuel is injected with low-pressure (= initial spray).

- Since the injection pump delivers more fuel than can be injected during the initial stroke, the pressure in the injector rises. Due to this the nozzle needle and the stop sleeve are lifted further against the force of spring no.2 (high spring rate). Now the nozzle needle opens by the main stroke, and the major amount of fuel is injected with high-pressure (= main spray). As a result, the pressure in the combustion chamber rises less sharply, so that the combustion is smoother and though quieter.

NOTE: Always replace the gaskets of the injector leak-off lines when removing them. As the leak-off lines are located under the cylinder head cover, fuel leaking from the lines can contaminate the engine oil. This results in oil dilution and hence in engine damage.

Diagnostics

- The high-pressure system can be checked as following:
 - Checking the start of fuel delivery
 - Checking the low-pressure part of the injection pump
 - Checking the function of the injectors (similar to the Zexel injection pump system)

Checking the low-pressure part of the injection pump

- Disconnect the connector of the spill valve (to prevent fuel injection). Then disconnect the fuel return line at the injection pump and connect a locally fabricated fuel line to the pump. The other end of this fuel line must go to a measuring container. Then crank the engine for approx. 10 s and check the amount of fuel delivered. If the fuel amount is far below or far above the reference value, the injection pump might be faulty.

NOTE: This test should only be performed, if the diagnostic check revealed that the low-pressure system from the fuel tank to the injection pump is intact.

Injection Amount Control

Features

- The injection amount control of the vehicles with RF-T engine has the following features:
 - Spill valve has been introduced.
 - Injector driver module
 - Injection pump PROM (similar to that of the Zexel injection pump system)
 - Fuel shut-off valve controlled by a relay has been introduced.
 - Fuel temperature sensor integrated in the injection pump (similar to that of the Denso common rail system)

Spill Valve

- The **SPV (Spill Valve)** controls the high-pressure phase duration of the axial-piston distributor pump and hence the fuel amount delivered to the injectors. As a result, the injection amount varies depending on the operating conditions of the engine. The SPV is located at the distributor head of the injection pump and consists of a coil and a spring-loaded spool valve. The position of the spool valve is controlled by the PCM, which drives the SPV via the injector driver module.

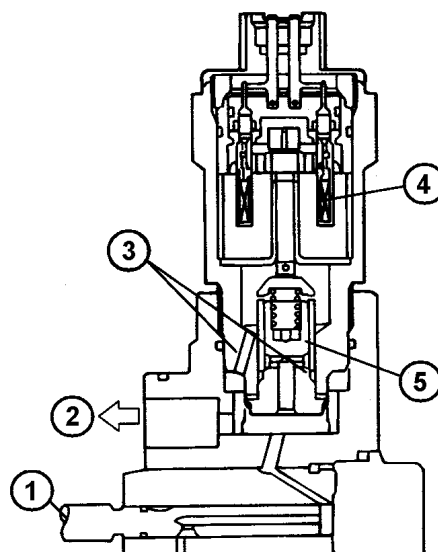

D S 14QT0281E

- 1 Distributor plunger
- 2 To pump chamber
- 3 Spill ports

- 4 Coil
- 5 Spool valve

- When the SPV is energized by the IDM, the spool valve closes the additional passage between high-pressure chamber and pump chamber. Due to this the high-pressure phase starts, i.e. fuel is delivered to the injectors.

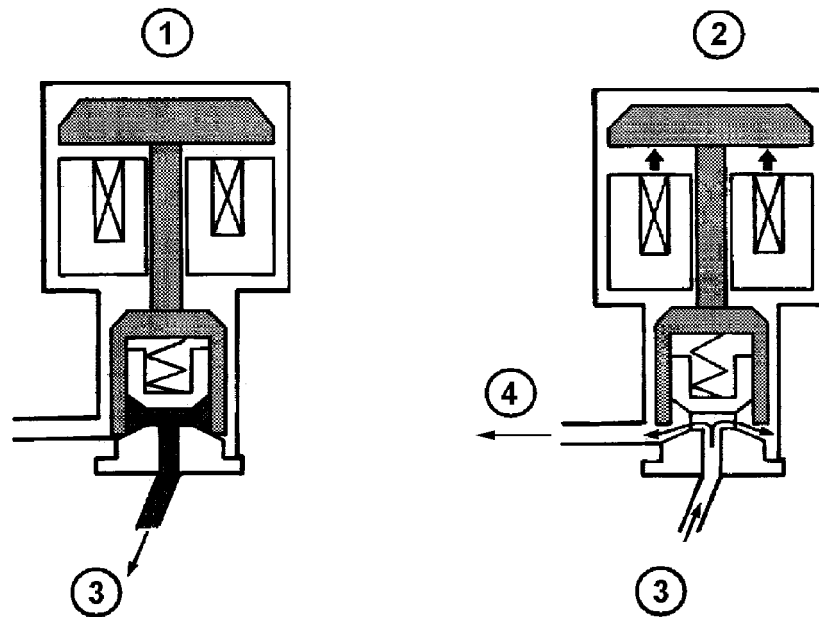

D S 5QT0274-75E

- | | | | |
|---|------------|---|-------------------------------|
| 1 | SPV closed | 3 | To/From high pressure chamber |
| 2 | SPV open | 4 | To pump chamber |

- When the SPV is de-energized by the IDM, the spool valve opens the additional passage between the high-pressure chamber and the pump chamber. Due to this the high-pressure phase ends, i.e. no more fuel is delivered to the injectors.
- In addition, the SPV serves to shut off the engine. When the ignition is switched off, the SPV is de-energized by the IDM. The spring force causes the spool valve to adopt in the open position, setting the injection amount to zero.

NOTE: When the SPV fails the spool valve adopts in the open position and sets the injection amount to zero. AsAs a result, the engine stalls and does not start anymore.

- The closing time of the SPV determines the duration of the high-pressure phase, changing the injection amount from zero to maximum.

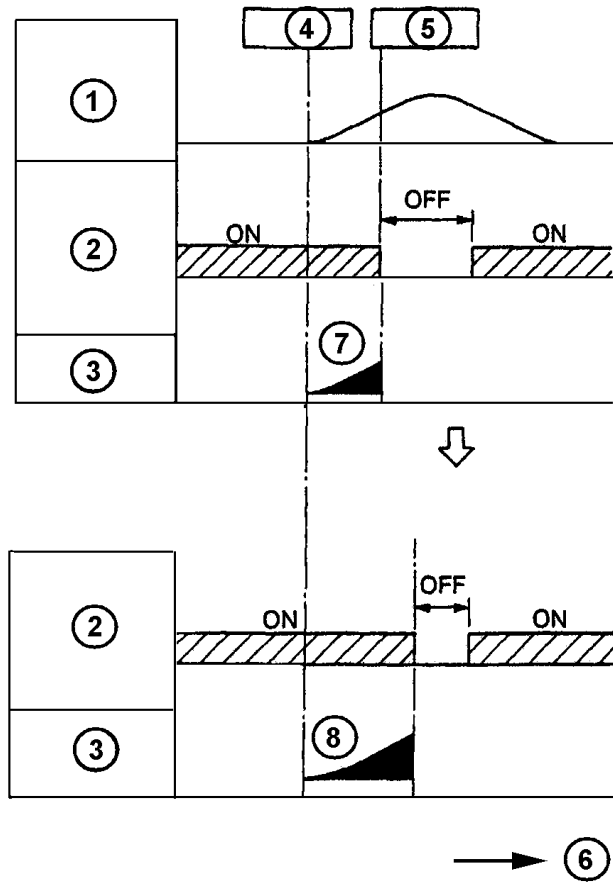

M 1614 F2-36 u

- | | | | |
|---|--------------------|---|------------------------|
| 1 | Cam lift | 5 | End of injection |
| 2 | SPV control | 6 | Cam angle |
| 3 | Injection amount | 7 | Small injection amount |
| 4 | Start of injection | 8 | Large injection amount |

Injector Driver Module

- The IDM drives the SPV according to the control signals from the PCM. It has a high-voltage generator inside, which amplifies the battery voltage input from the SPV relay into a high voltage of approx. 150 V and stores it in a capacitor. A control circuit outputs the high voltage to the SPV as a drive signal. The IDM is controlled by the PCM via a duty signal.

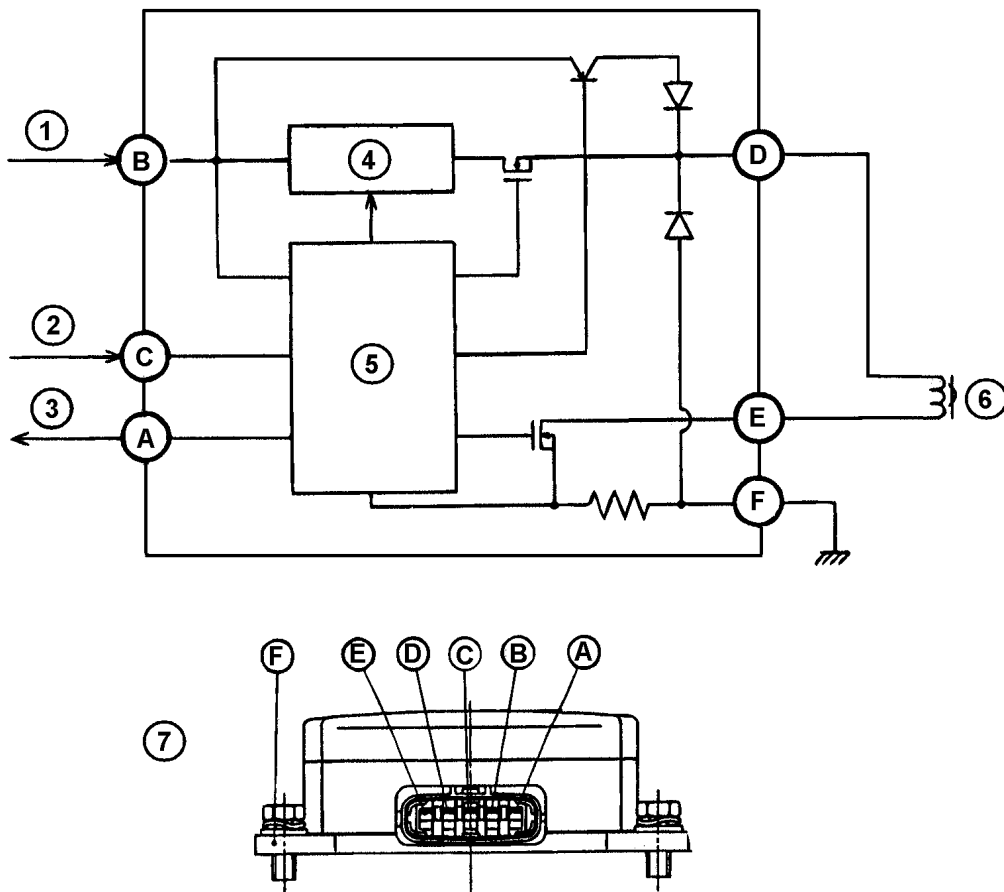

D S 42QT0129E

- | | |
|--------------------------|-------------------|
| 1 From SPV relay | 5 Control circuit |
| 2 SPV control signal | 6 SPV |
| 3 Feedback signal | 7 Connector |
| 4 High-voltage generator | |

- The IDM actuates the SPV in three phases. When the SPV control signal is input from the PCM, the IDM energizes the SPV with a high voltage of approx. 150 V (= pull-up phase). Due to the high pull-up current (approx. 12 A) the valve closes rapidly.
- In the holding phase the IDM reduces the actuating voltage to 12 V, resulting in a lower holding current (approx. 6 A). Due to this the power loss in the IDM and in the SPV is minimized, avoiding unnecessary heat in these components.
- In the turn-off phase, the PCM cuts off the actuating voltage to open the SPV.
- While the SPV is closed the IDM detects the drive current and outputs a feedback signal to the PCM to facilitate failure detection.

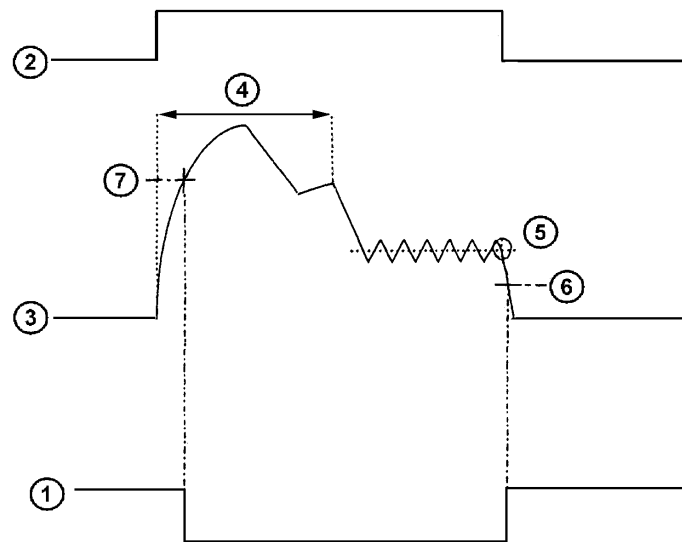

M 1614 F2-34

- | | | | |
|---|--------------------------------|---|-------------------------|
| 1 | Feedback signal | 5 | Holding current |
| 2 | SPV control signal | 6 | Fail signal (Low side) |
| 3 | SPV drive current | 7 | Fail signal (High side) |
| 4 | Pull-up current switching time | | |

- When the required injection amount is small, the PCM controls the IDM with a small duty cycle, so that the drive signal outputted to the SPV is short. Due to this the closing time of the SPV during the high-pressure phase is short, resulting in a small injection amount.
- When the required injection amount is large, the PCM controls the IDM with a large duty cycle, so that the drive signal outputted to the SPV is long. Due to this the closing time of the SPV during the high-pressure phase is long, resulting in a large injection amount.

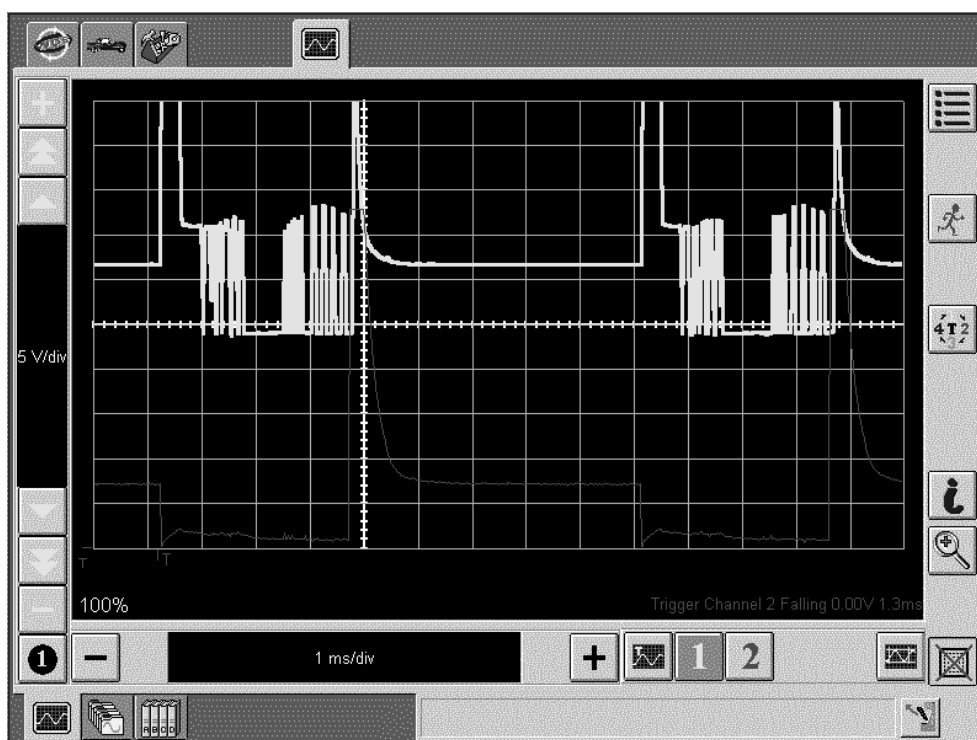

SPV Signal

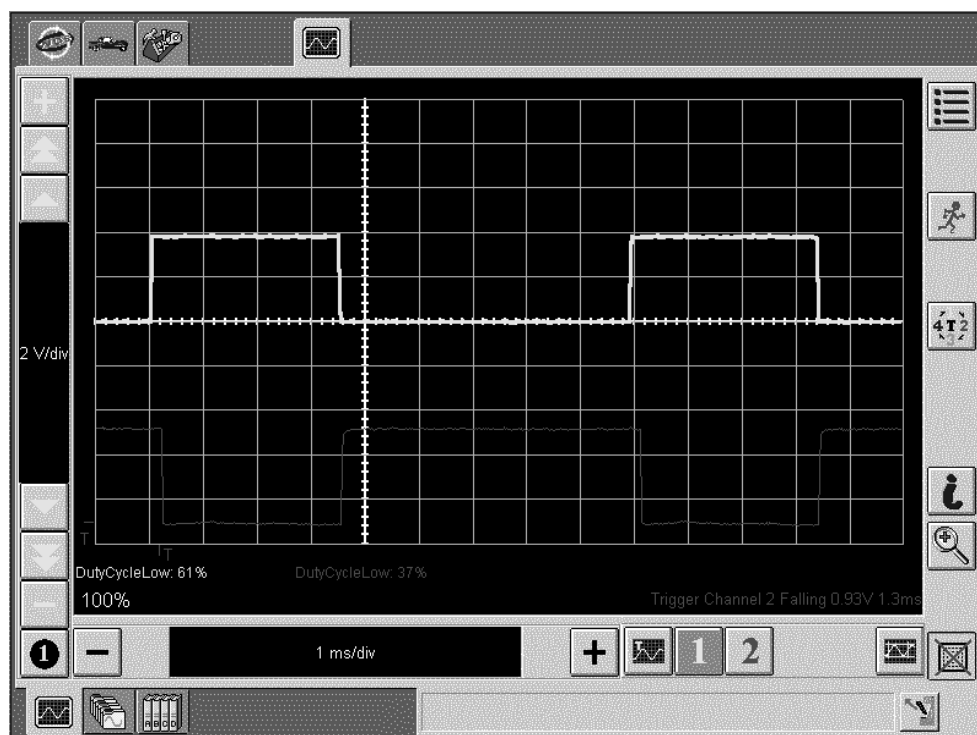

IDM Signal

Fuel Shut-off Valve

- On the vehicles with RF-T engine the FSOV serves only as a stand-by shut-off in case the SPV should fail. The valve operates similar to that of the Zexel injection pump system, i.e. it closes the inlet passage to the high-pressure chamber when de-energized.
- The FSOV is controlled by the PCM via the FSOV relay. In addition, the PCM monitors the output voltage of the FSOV relay to facilitate failure detection.

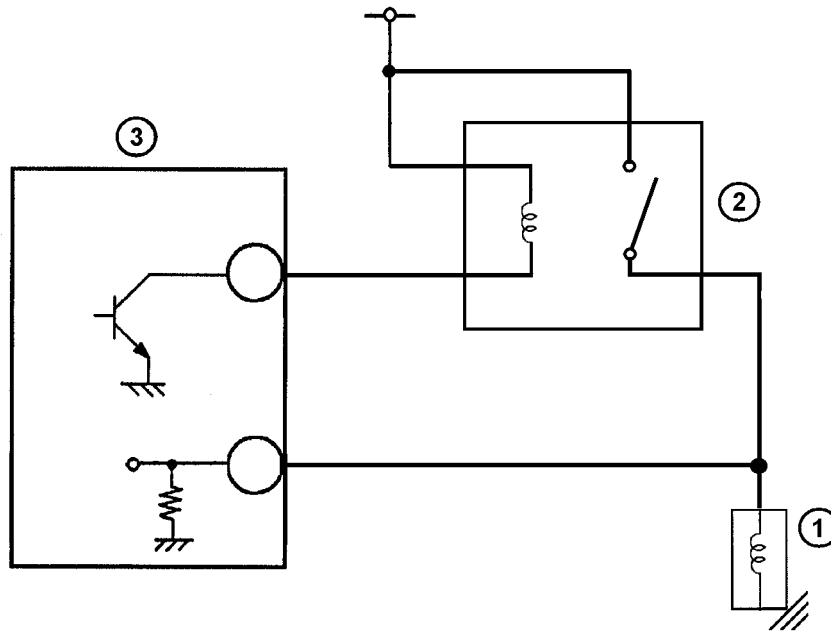

1 FSOV
2 FSOV relay

3 PCM

A_C compressor

Diagnostics

- The components of the injection amount control can be checked as following:
 - Checking the voltage signal of the SPV
 - Checking the resistance of the SPV
 - Checking the voltage at the SPV relay
 - Checking the voltage signal to the IDM
 - Monitoring the FLT sensor via the PID **FLT/FLT V** (Temp/Volt)
 - Checking the voltage of the FLT sensor
 - Checking the resistance of the FLT sensor
 - Monitoring the FSOV relay via the PID **FSOV** (Mode)
 - Checking the voltage at the FSOV relay
 - Checking the voltage at the FSOV
 - Checking the resistance of the FSOV

Injection Timing Control

Features

- The injection timing control of the vehicles with RF-T engine has the following features:
 - Timer device with timer control valve
 - Timer position sensor has been cancelled.
 - Pump speed sensor mounted on the roller ring has been introduced.

Pump Speed Sensor

- Vehicles with RF-T engine feature an inductive-type pump speed sensor, which is mounted on the roller ring of the axial-piston distributor pump and scans a rotor with 52 teeth. According to the number of cylinders the rotor has four tooth gaps spread evenly around the circumference. The signal of the pump speed sensor is used to detect the position of the roller ring, giving a feedback about the actual injection timing to the PCM.

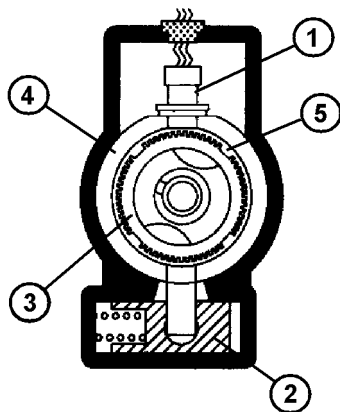

TS 13

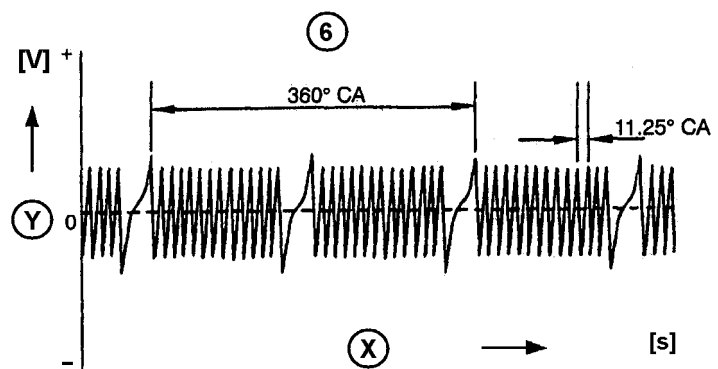

M 1614 F2-30 o re

- X Time
- 1 Pump speed sensor
- 2 Timer piston
- 3 Toothed rotor

- Y Output voltage
- 4 Roller ring
- 5 Tooth gap
- 6 Output voltage characteristics

- When the injection timing is altered by the timer device the roller ring and hence the pump speed sensor is turned in the “advance” or “retard” direction, changing the position of the sensor in relation to the rotor. Thus the voltage characteristics of the pump speed sensor signal also changes in relation to the CKP sensor signal. The PCM calculates the phase difference between both signals and thereby determines an accurate position of the roller ring.
- In addition, the PCM uses the pump speed sensor signal to detect the position of the distributor plunger, determining the time at which the SPV must be actuated. Actuation must take place at precisely the correct crank angle, so that the SPV closes and opens at the appropriate position of the distributor plunger. This ensures that the start of fuel injection and the injection amount are correct.

NOTE: When the pump speed sensor fails, the engine stalls and does not start anymore.

- The pump speed sensor supplies the PCM with an alternating voltage between 2...9 V (peak to peak).

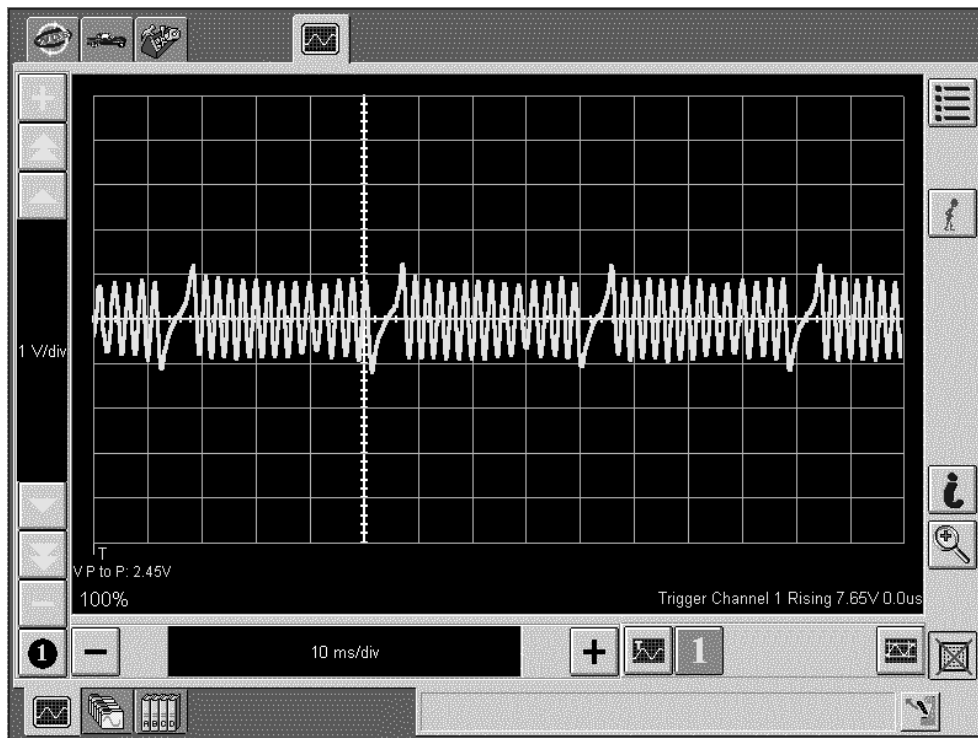

RPM Signal

Diagnostics

- The components of the injection timing control can be checked as following:
 - Monitoring/Activating the TCV via the PID **TCV** (Per)
 - Checking the voltage signal of the TCV
 - Checking the resistance of the TCV
 - Monitoring the pump speed sensor via the PID **RPM** (Rpm)
 - Checking the voltage signal of the pump speed sensor
 - Checking the resistance of the pump speed sensor

Emission System

Parts Location

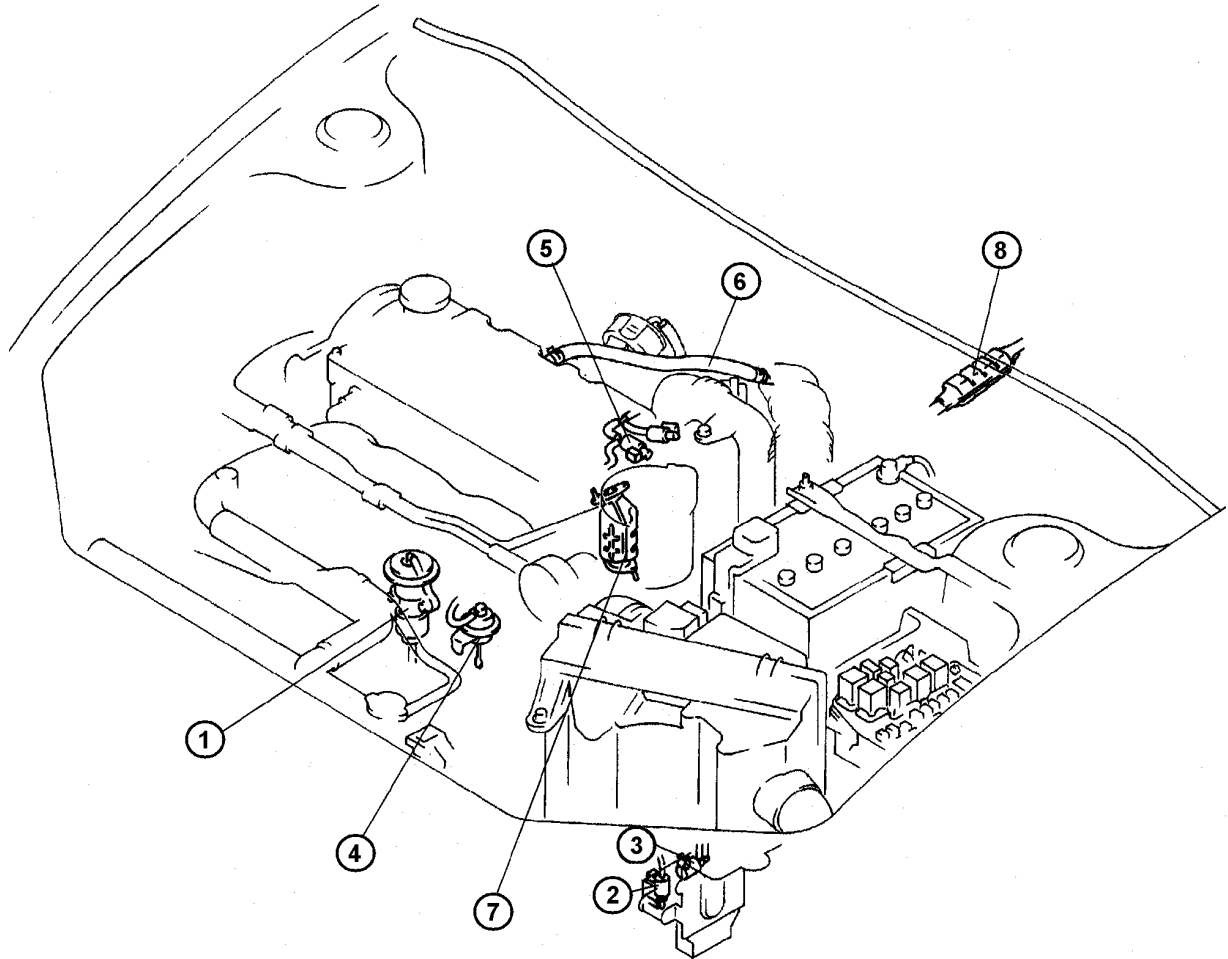

- 1 EGR valve
- 2 EGR ventilation solenoid valve
- 3 EGR vacuum solenoid valve
- 4 ISV vacuum actuator

- 5 ISV solenoid valve
- 6 Crankcase ventilation hose
- 7 Warm-up oxidation catalytic converter
- 8 Oxidation catalytic converter

M 1704 F5-9

System Overview

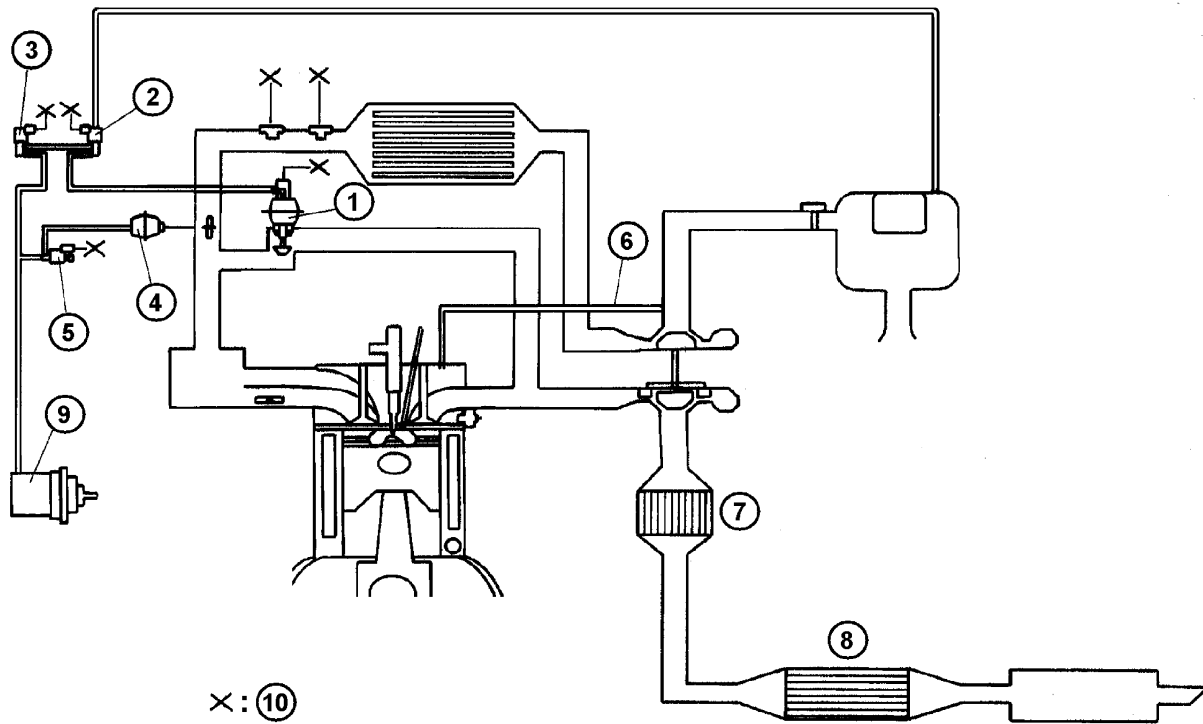

M 1688 F2-21

- 1 EGR valve
- 2 EGR ventilation solenoid valve
- 3 EGR vacuum solenoid valve
- 4 ISV vacuum actuator
- 5 ISV solenoid valve

- 6 Crankcase ventilation hose
- 7 Warm-up oxidation catalytic converter
- 8 Oxidation catalytic converter
- 9 Vacuum pump
- 10 To PCM

Exhaust System

Features

- The exhaust system of the vehicles with RF-T engine has the following features:
 - Warm-up oxidation catalytic converter for Euro 3 vehicles (similar to that of the Denso common rail system)
 - Oxidation catalytic converter (similar to that of the Denso common rail system)

Exhaust Gas Recirculation System

Features

- The exhaust gas recirculation system of the vehicles with RF-T engine has the following features:
 - EGR valve with vacuum actuator for Euro 3 vehicles (similar to that of the Denso common rail system)
 - EGR valve with vacuum actuator and position sensor for EOBD vehicles (similar to that of the Denso common rail system)
 - EGR vacuum and EGR ventilation solenoid valve
 - EGR control solenoid valve has been cancelled.
 - EGR cooler has been cancelled
 - Two-step intake shutter valve with vacuum actuator for Euro 3 vehicles (similar to that of the Zexel injection pump system)
 - ISV solenoid valve for Euro 3 vehicles (similar to that of the Zexel injection pump system)

Control System

Parts Location

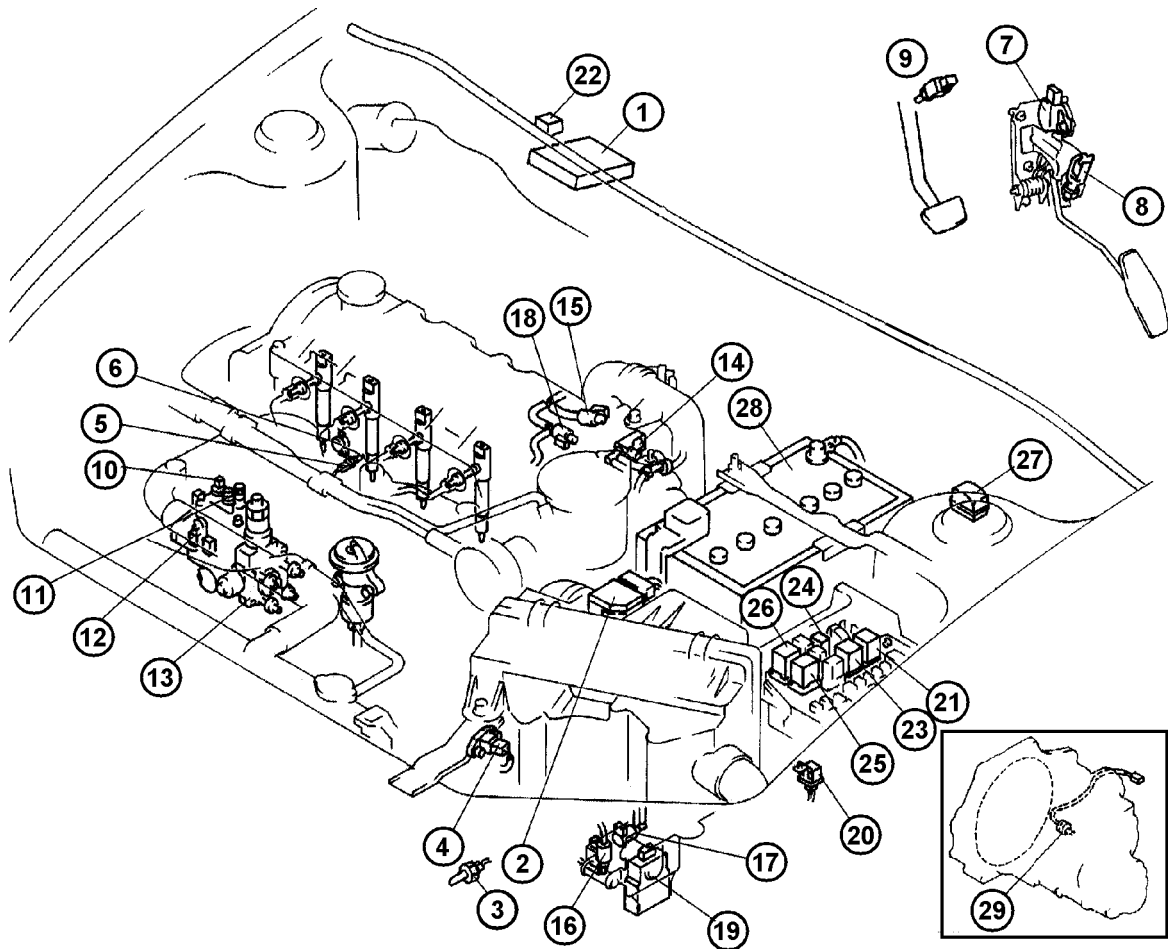

M 1704 F5-10

- | | | | |
|----|--|----|--------------------------------|
| 1 | PCM (incl. barometric pressure sensor) | 16 | EGR ventilation solenoid valve |
| 2 | MAF/IAT sensor | 17 | EGR vacuum solenoid valve |
| 3 | IAT sensor | 18 | ISV solenoid valve |
| 4 | MAP sensor | 19 | IDM |
| 5 | Engine coolant temperature sensor | 20 | Glow plug relay |
| 6 | Crankshaft position sensor | 21 | SPV relay |
| 7 | Accelerator pedal position sensor | 22 | FSOV relay |
| 8 | Idle switch | 23 | PCM control relay |
| 9 | Clutch pedal position switch | 24 | A/C relay |
| 10 | FLT sensor | 25 | Condenser fan relay |
| 11 | Pump speed sensor | 26 | Cooling fan relay |
| 12 | Injection pump PROM | 27 | Data link connector |
| 13 | TCV | 28 | Battery |
| 14 | VBC solenoid valve | 29 | Park / Neutral position switch |
| 15 | VSC solenoid valve | | |

Block Diagram

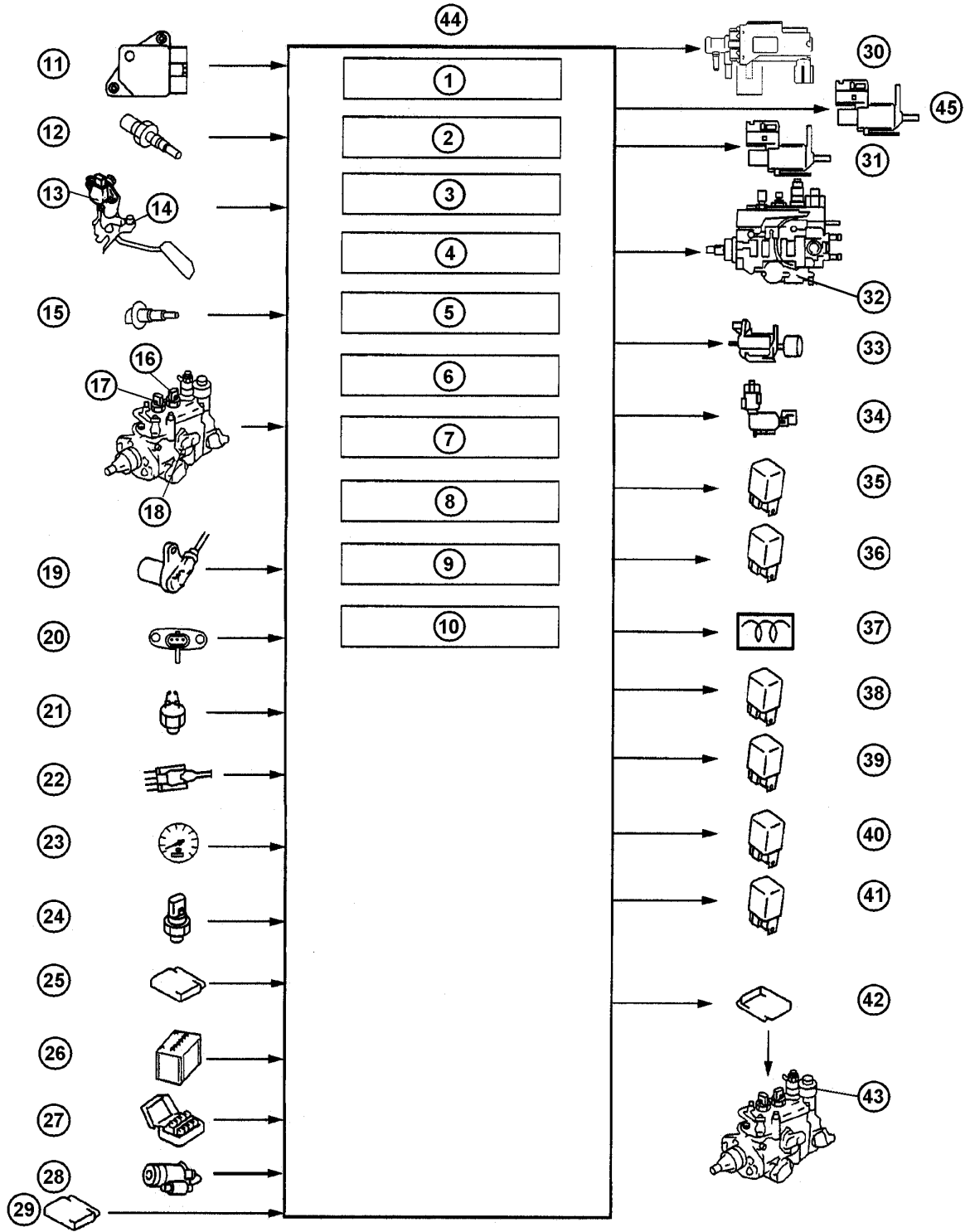

M 1688 F2-26

Control System

Denso Injection Pump System

1	Injection amount control	24	Refrigerant pressure switch (with A/C)
2	Injection timing control	25	Immobilizer module
3	Idle speed control	26	Battery
4	Glow control	27	Data link connector
5	EGR control	28	Starter (starter signal)
6	VBC	29	Barometric pressure sensor (in PCM)
7	VSC	30	VBC solenoid valve
8	Electrical fan control	31	VSC solenoid valve
9	A/C control (if equipped)	32	TCV
10	Immobilizer system	33	EGR vacuum solenoid valve
11	MAF/IAT sensor	34	EGR ventilation solenoid valve
12	Engine coolant temperature sensor	35	SPV relay
13	Accelerator pedal position sensor	36	FSOV relay
14	Idle switch	37	Glow indicator light
15	IAT sensor	38	Glow plug relay
16	Pump speed sensor	39	A/C relay (with A/C)
17	FLT sensor	40	Cooling fan relay
18	Injection pump PROM	41	Condenser fan relay (with A/C)
19	Crankshaft position sensor	42	IDM
20	MAP sensor	43	SPV
21	Park / Neutral position switch	44	PCM
22	Clutch pedal position switch	45	ISV solenoid valve
23	Vehicle speed sensor		

Relationship Chart

x: Applicable

Device		Control item									
		Injection amount control	Injection timing control	Idle speed control	Glow control	EGR control	VBC	VSC	Electrical fan control	A/C control	Immobilizer system
Input	Engine coolant temperature sensor	X	X	X	X	X	X	X	X	X	
	Accelerator pedal position sensor	X		X		X	X	X	X	X	
	Idle switch	X	X	X		X		X	X		
	MAF/IAT sensor		X			X		X			
	IAT sensor No.2	X									
	Pump speed sensor	X	X	X		X	X	X	X	X	
	FLT sensor	X									
	Injection pump PROM	X	X								
	Crankshaft position sensor		X			X					
	MAP sensor	X	X				X				
	Park / Neutral position switch	X	X	X		X		X		X	
	Clutch pedal position switch	X	X	X		X		X		X	
	Vehicle speed sensor	X	X	X	X			X		X	
	Barometric pressure sensor (integrated in PCM)					X	X	X			
	Refrigerant pressure switch (with A/C)			X					X	X	
	Immobilizer module										X
	Battery voltage				X						
	DLC (TEN terminal)								X		
	Starter signal	X	X			X	X	X		X	
Output	VBC solenoid valve						X				
	VSC solenoid valve							X			
	TCV		X								
	EGR solenoid valve (vacuum, vent)					X					
	Spill valve relay	X								X	
	FSOV relay	X								X	
	Glow indicator light				X						
	Glow plug relay				X						
	A/C relay								X	X	
	Cooling fan relay								X		
	Condenser fan relay (with A/C)								X		
	ISV solenoid valve					X					
	IDM	X		X							X

Denso IP Rel

Powertrain Control Module

Features

- The powertrain control module of the vehicles with RF-T engine has the following features:
 - Read-only memory (similar to that of the Denso common rail system)
 - Random-access memory with keep-alive power supply (similar to that of the Denso common rail system)

Sensors

Features

- The sensors of the vehicles with RF-T engine have the following features:
 - Inductive-type crankshaft position sensor
 - Potentiometer-type accelerator pedal position sensor (similar to that of the Denso common rail system)
 - Idle switch (similar to that of the Denso common rail system)
 - Engine coolant temperature sensor (similar to that of the Denso common rail system)
 - Barometric pressure sensor integrated in PCM for Euro 3 vehicles (similar to that of the Denso common rail system)
 - Clutch pedal position switch and park/neutral position switch with joint PCM terminal for both sensors

Crankshaft Position Sensor

- Vehicles with RF-T engine feature an inductive-type CKP sensor (also termed as TDC sensor), which scans a rotor with one tooth.

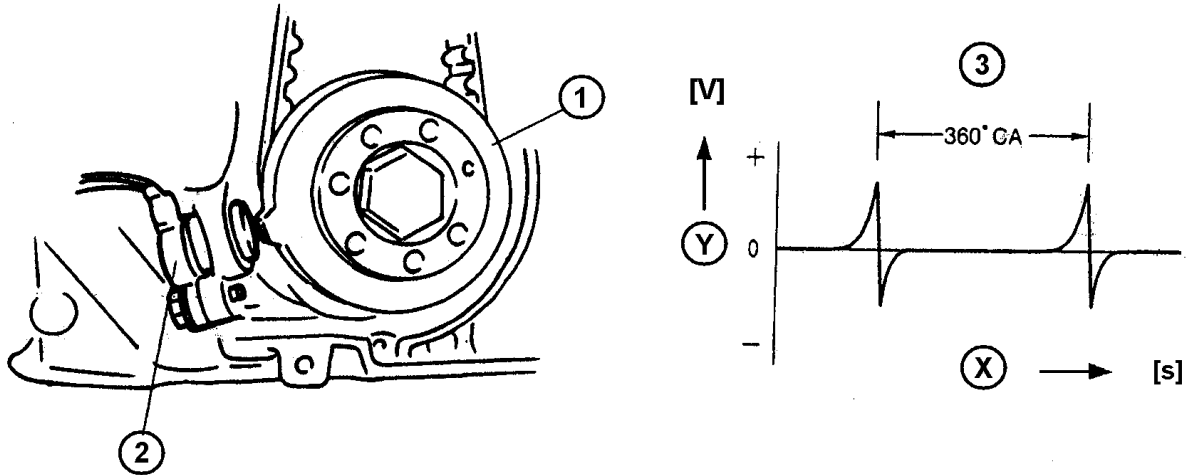

M 1614 F2-31

- | | | | |
|---|---------------|---|--------------------------------|
| X | Time | Y | Output voltage |
| 1 | Toothed rotor | 3 | Output voltage characteristics |
| 2 | CKP sensor | | |

NOTE: When the CKP sensor fails, the TCV adopts in the closed position, advancing the injection timing. This can be recognized by the increased engine noise at idle (Diesel knocking).

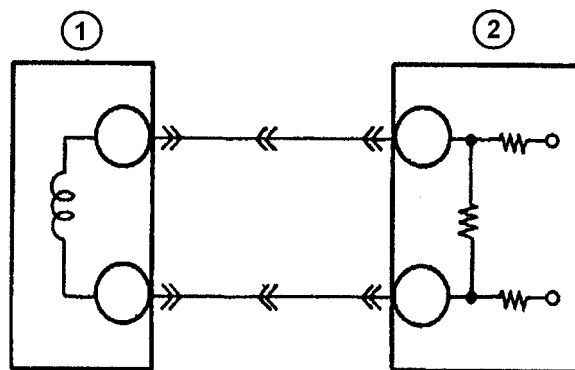

M EGI S169 m

- | | | | |
|---|------------|---|-----|
| 1 | CKP sensor | 2 | PCM |
|---|------------|---|-----|

- The CKP sensor supplies the PCM with an alternating voltage between 6...18 V (peak to peak).

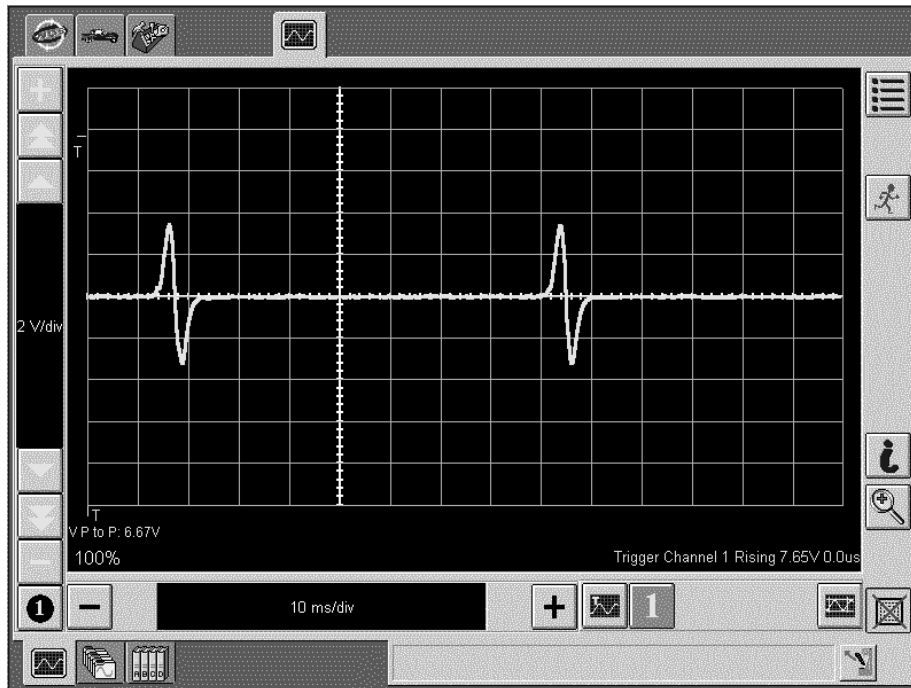

CKP Signal

Diagnostics

- The CKP sensor can be checked as following:
 - Checking the voltage signal
 - Checking the resistance

Actuators

Features

- The actuators of the vehicles with RF-T engine have the following features:
 - Glow plug relay with feedback to the PCM (similar to that of the Denso common rail system)
 - Cooling fan for vehicles without A/C (similar to that of the Denso common rail system)
 - Cooling fan and condenser fan for vehicles with A/C (similar to those of the Denso common rail system)
 - A/C compressor (similar to that of the Denso common rail system)
 - Immobilizer system with separate immobilizer module

Immobilizer System

- Vehicles with RF-T engine are equipped with a separate immobilizer module. The PCM deactivates the FSOV and the IDM, when the vehicle is started with an invalid key. On vehicles with starter relay the immobilizer system disables the starter as well. As a result the engine doesn't even crank.
- If a vehicle without starter relay is started with an invalid key, the PCM allows the engine to start but cuts off the fuel supply after approx. 2 s, stopping the engine. After three attempts to start the engine with an invalid key the PCM permanently cuts off the fuel supply. As a result, the engine cranks but does not start.

NOTE: If a vehicle without starter relay starts and stalls after a few seconds or cranks and doesn't start, verify that this concern isn't related to the immobilizer system by observing the immobilizer warning light.

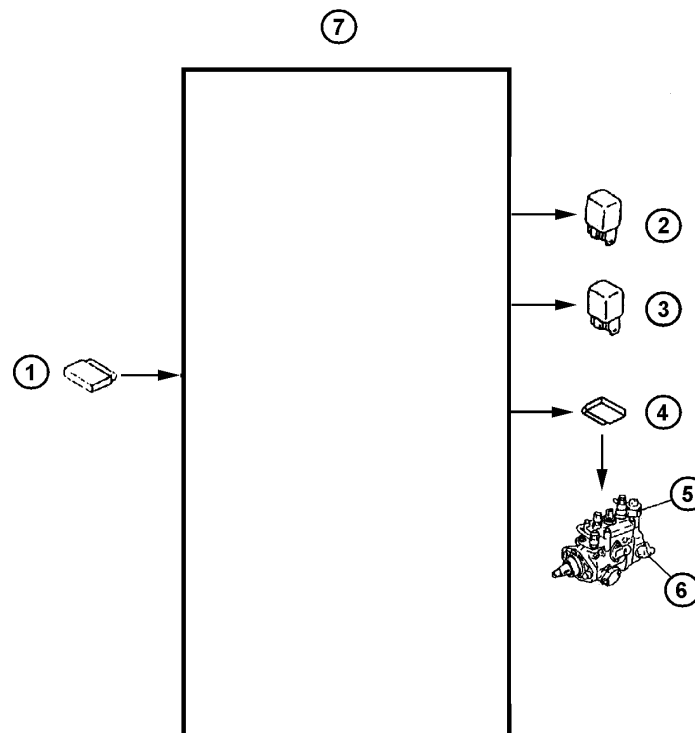

M 1614 F2-47_27

- | | | | |
|---|--------------------|---|------|
| 1 | Immobilizer module | 5 | SPV |
| 2 | SPV relay | 6 | FSOV |
| 3 | FSOV relay | 7 | PCM |
| 4 | IDM | | |

NOTE: For diagnosis on the immobilizer system refer to the workshop manual (section T – Immobilizer System).

On-board Diagnostic System

On-board Diagnostic System

General

- The **OBD (On-Board Diagnostic)** system is integrated in the PCM and checks the overall engine management system for malfunctions. If a malfunction is detected, a corresponding diagnostic trouble code is stored in the fault memory. Then the malfunction indicator light is illuminated in order to alert the driver to the malfunction. A serial interface allows access to the engine-related diagnostic information with WDS, providing the basis for an efficient diagnosis and repair.

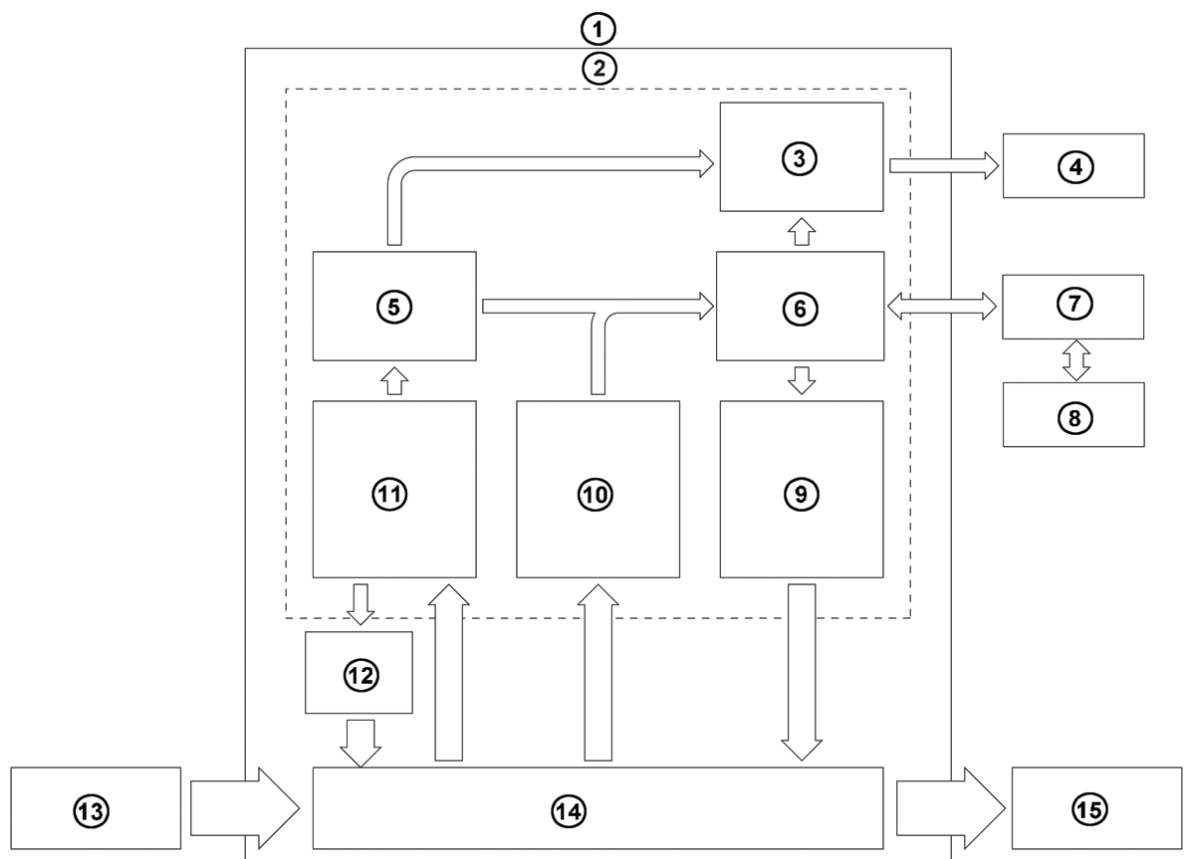

BHE0102T001

- | | | | |
|---|-----------------------------|----|--------------------------|
| 1 | PCM | 9 | Simulation test function |
| 2 | On-board diagnostic system | 10 | PID monitor function |
| 3 | MIL driver | 11 | Fault detection function |
| 4 | Malfunction indicator light | 12 | Fail-safe function |
| 5 | Fault memory | 13 | Sensors |
| 6 | Serial interface | 14 | Engine control system |
| 7 | Data link connector | 15 | Actuators |
| 8 | WDS | | |

Malfunction Indicator Light

- The **MIL (Malfunction Indicator Light)** is located in the instrument cluster and serves to alert the driver to a malfunction in the engine management system. During normal operation the MIL illuminates when the ignition is on and is extinguished when the engine has started. If the MIL stays on after engine start or comes up during driving, then the OBD system has detected a fault.

NOTE: If the MIL does not illuminate when the ignition is on, or stays on after engine start but no fault is stored in the PCM memory, this indicates a malfunction in the MIL control circuit.

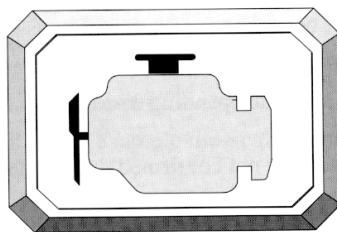

F EOBD S18 7856_36

- On Mazda vehicles without MIL the glow indicator light flashes, when the OBD system has detected a fault.

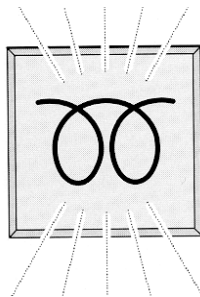

F 7987 S30 T3

- If the fault does not reoccur and the PCM has exit the fail-safe mode, the MIL or the glow indicator light is extinguished automatically.

On-board Diagnostic System

Data Link Connector

- The **DLC (Data Link Connector)** is the interface between the OBD system and WDS, and allows access to the engine-related diagnostic information.
- Newer Mazda vehicles (except for B2500 UN with WL-3/WLT-3 engine) and all EOBD vehicles are equipped with a 16-pin DLC (also termed as DLC-2) in the passenger compartment (near the steering column). The connector and the data communication protocols are standardized, i.e. the engine-related diagnostic information can also be accessed via a generic scan tool.

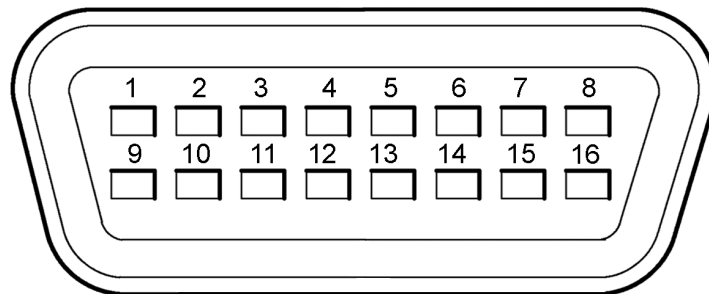

77-59-37-ESG

Terminal	Description
4	Ground
5	Ground
6	HS-CAN High
7	KLN
14	HS-CAN Low
16	Battery power supply
Others	Not in use for OBD

On-board Diagnostic System

- The B2500 UN with WL-3/WLT-3 engine and other Mazda vehicles are equipped with a 17-pin DLC (also termed as DLC-1) in the engine compartment (near the left suspension strut). The connector is not standardized, i.e. the engine-related diagnostic information can only be accessed via WDS.
- Furthermore, the 17-pin DLC features eight additional pins, which allow to check the engine tune-up or to retrieve an engine speed signal.

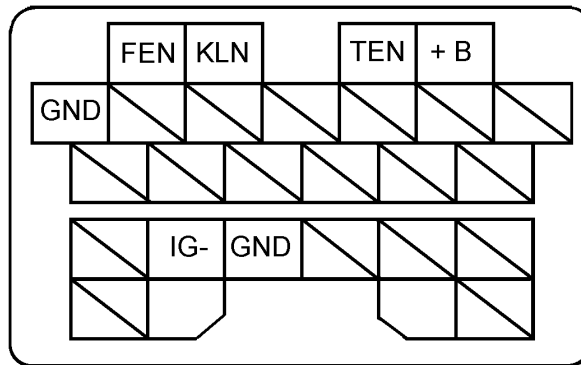

M 5534 S 42

Terminal	Description
FEN	Data of DTC read-out
KLN	Serial interface
TEN	Triggering for DTC read-out and engine tune-up
+B	Ignition power supply
GND	Ground
IG-	Engine speed signal
Others	Not in use for OBD

On-board Diagnostic System

Diagnostic Trouble Codes

- After a fault has been detected a corresponding **DTC (Diagnostic Trouble Code)** is stored in the PCM memory and can be read out with WDS. A DTC is defined as a 5-digit alphanumeric code (e.g. P0116) containing the information shown below.

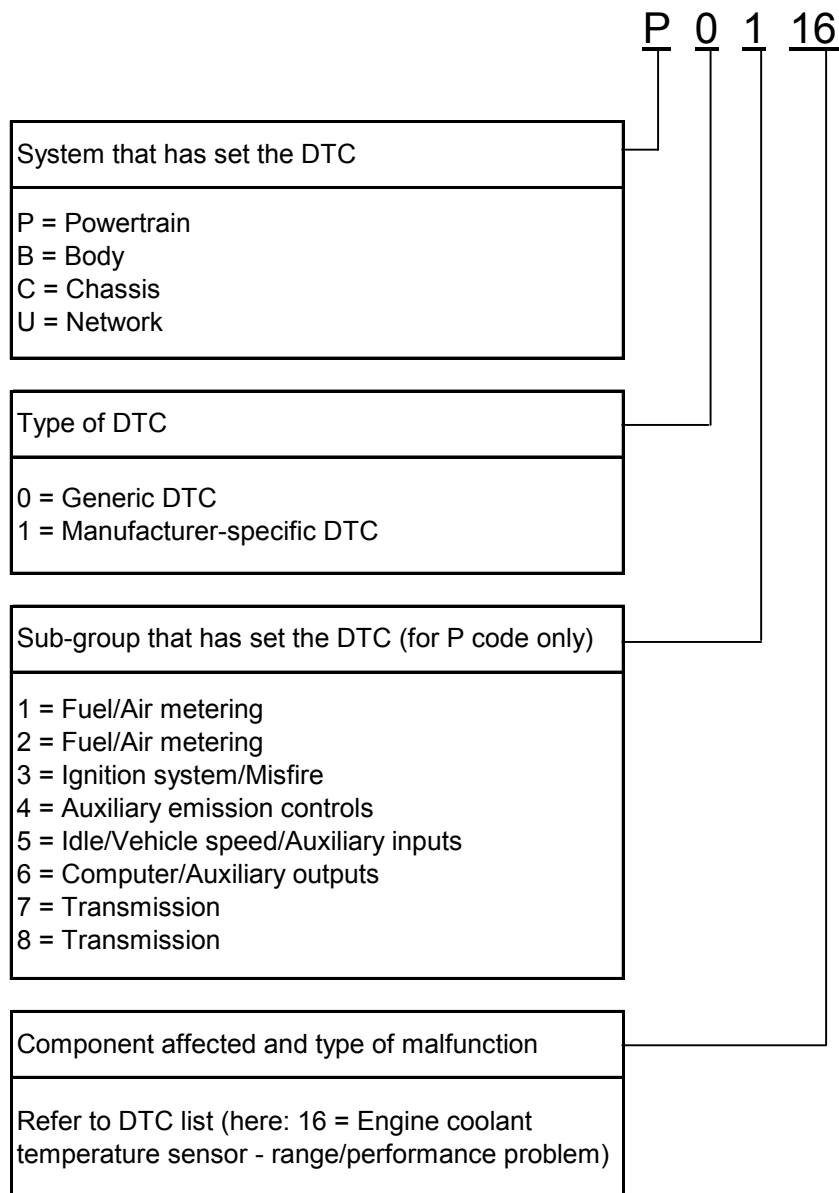

DTC3004

DTC Status

- When reading out **CMDTCs** (**C**ontinuous **M**emory **D**TCS) on a vehicle with HS-CAN bus, the WDS displays an additional status information behind each DTC (e.g. P0405-**E2**). A corresponding description for the DTC status can be found on the right-hand side of the WDS screen.

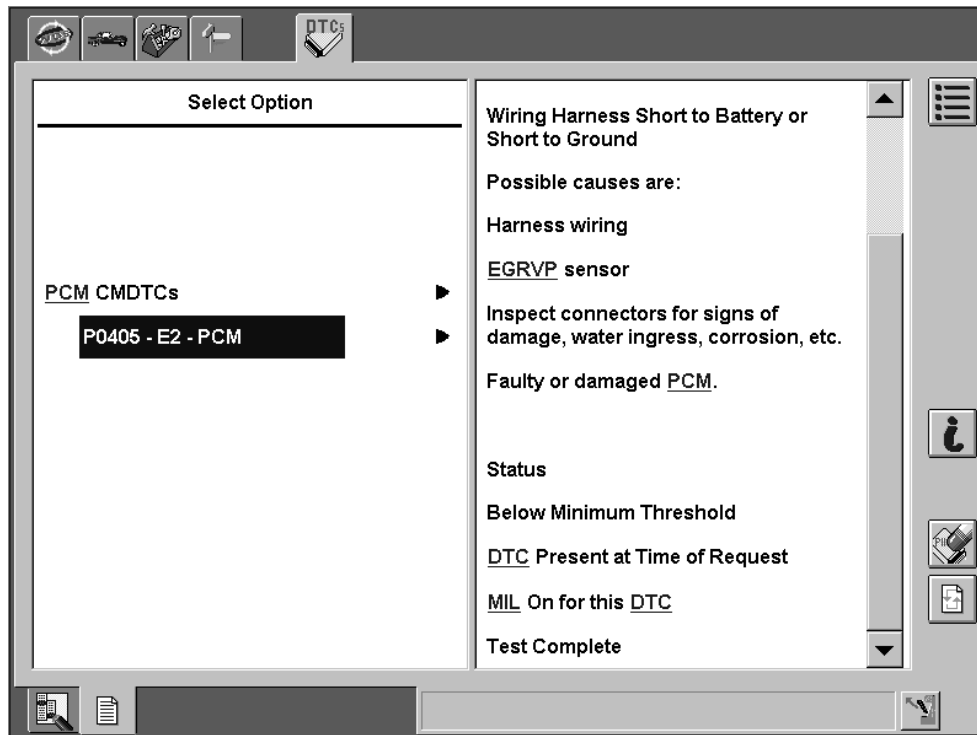

m3 dtc3

- The DTC status is defined as a two-digit alphanumeric code. The first digit indicates, whether the fault is present at the time of DTC read-out and whether the MIL is on for this fault. The second digit provides information about the fault symptom (e.g. signal above or below threshold, no signal etc.). The following status information is used:

DTC Status	Description
2x	DTC not present, MIL OFF
6x	DTC present, MIL OFF
Ax	DTC not present, MIL ON
Ex	DTC present, MIL ON
FF	No status available

“x” can be any number and indicates the fault symptom

On-board Diagnostic System

- The DTC status is very helpful to determine whether a malfunction is present when the vehicle is in the workshop or not. If e.g. a customer has complained about poor engine power on his Mazda3 with 1.6 MZ-CD engine and the DTC P1412-61 (EGR valve frozen) is stored, then the fault is momentary present on the vehicle and it should be easy to fix the problem (e.g. connector of the EGR valve loose).
- If the DTC P1412-21 is stored, then the fault is momentary not present on the vehicle and it might be difficult to rectify the concern. However, since the fault might occur only under certain operating conditions (e.g. vehicle operation at very low ambient temperatures), it should not be disregarded as a fault that has cured itself.

Fault Detection Function

- The fault detection function is integrated in the PCM and monitors the sensors, actuators and PCM-internal components for malfunctions. Different monitoring strategies are used depending on the component concerned.

Monitoring Strategy for Sensors

- The sensors of the engine management system are monitored for electrical faults, range faults and plausibility faults. Therefore the fault detection function measures the signal voltage of the sensors.

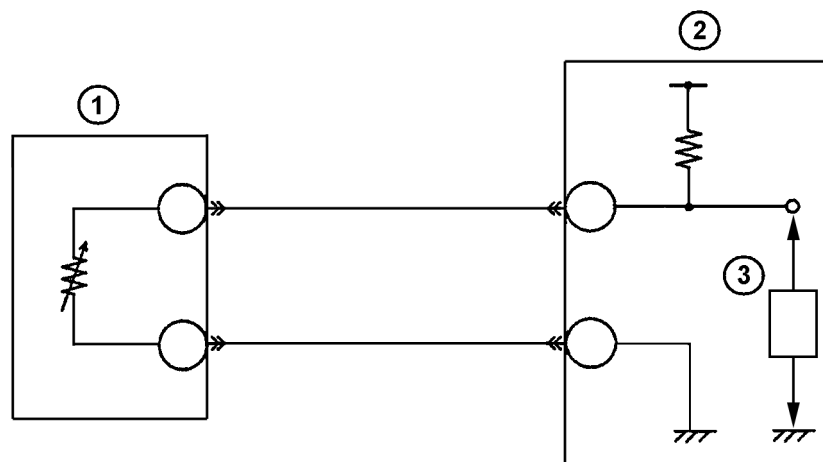

M 1737 F5-150

1 Sensor
2 PCM

3 Voltage detection circuit

Electrical Faults

- In order to detect electrical faults the fault detection function permanently compares the signal voltage measured to the limits for open circuit and short circuit to ground. If the signal voltage exceeds the upper limit (e.g. more than 4.9 V), the fault detection function determines that an open circuit exists. If the voltage measured exceeds the lower limit (e.g. less than 0.4 V), then this indicates a short circuit to ground.

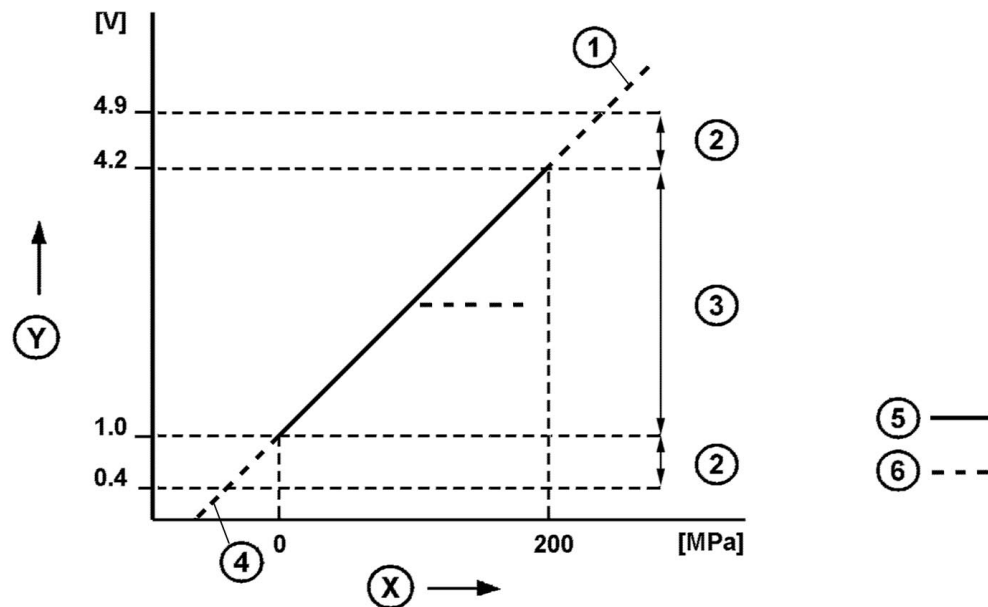

EL F 3004

X	Physical parameter (here: pressure)	Y	Output voltage
1	Open circuit	4	Short circuit to ground
2	Range fault	5	Correct signal
3	Plausibility fault	6	Faulty signal

Range Faults

- In order to detect range faults the fault detection function permanently compares the signal voltage measured to the measuring range of the sensor. If the signal voltage exceeds the specified range (e.g. less than 1 V or more than 4.2 V), the fault detection function determines that a range fault exists.

On-board Diagnostic System

Plausibility Faults

- In order to detect plausibility faults the fault detection function compares the signal voltage measured to other parameters of the engine management system by means of logical aspects. These parameters are derived from the momentary operating conditions of the engine and define an expected range for the sensor signals.
- If the signal voltage exceeds this range (e.g. the difference between the mass air flow detected by the MAF sensor and the mass air flow derived from engine displacement and CKP sensor signal is too high), the fault detection function determines that a plausibility fault exists.

Monitoring Strategy for Actuators

- The actuators of the engine management system are monitored for electrical faults and functional faults. Therefore the fault detection function measures the control voltage or the control current of the actuators.

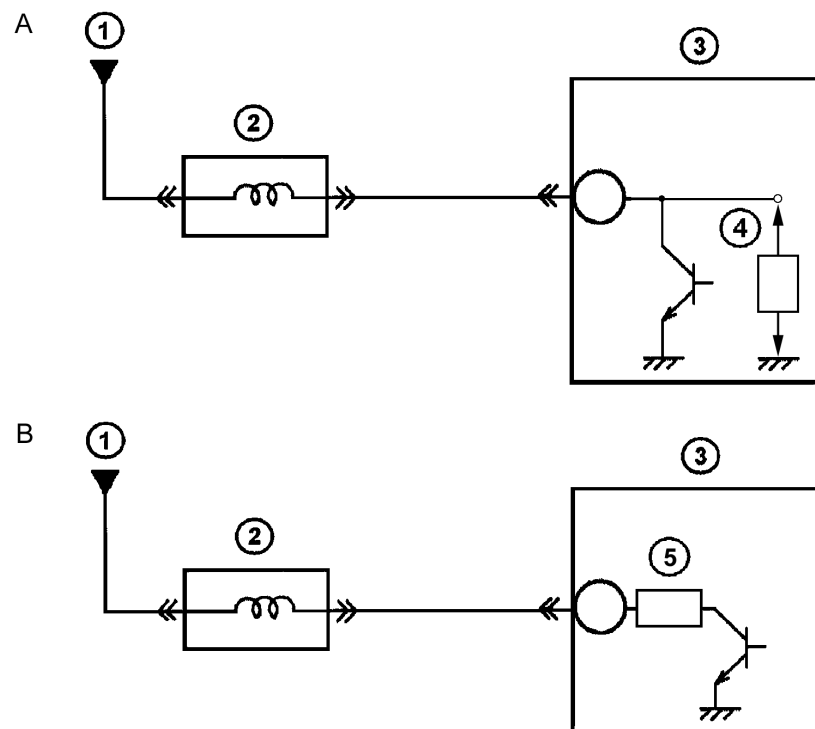

S-EGR 3004

- | | | | |
|---|--|---|--|
| A | Monitoring the control voltage of the actuator | B | Monitoring the control current of the actuator |
| 1 | From PCM control relay | 4 | Voltage detection circuit |
| 2 | Actuator | 5 | Current detection circuit |
| 3 | PCM | | |

Electrical Faults

- In order to detect electrical faults the fault detection function energizes the actuator in question for a short time (e.g. after switching the ignition on or during engine start) and compares the control voltage/control current measured to the limits for faulty control circuit, open circuit and short circuit to ground.
- If the control voltage/control current measured exceeds the upper/lower limit (e.g. more than 8 V/less than 1 A) when the actuator is energized, the fault detection function determines that the control circuit is faulty. If the control voltage/control current measured exceeds the lower/upper limit (e.g. less than 8 V/more than 1 A) when the actuator is de-energized, then this indicates an open circuit or a short circuit to ground.

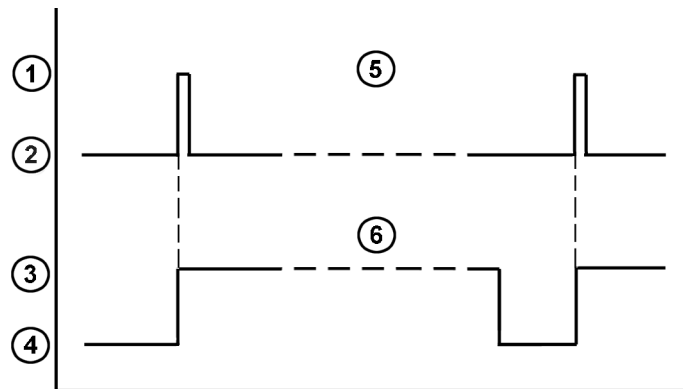

E53004

- | | | | |
|---|-----------------------------|---|----------------------|
| 1 | Actuator energized | 4 | Ignition OFF |
| 2 | Actuator de-energized | 5 | Actuator status |
| 3 | Ignition ON or engine start | 6 | Engine switch status |

Functional Faults

- In order to detect functional faults the fault detection function monitors other parameters of the engine management system by means of logical aspects, when the actuator in question is activated. These parameters are derived from the momentary operating conditions of the engine and show the reaction of the system, which is influenced by the actuator.
- If the reaction of the system does not correspond to the control signals output to the actuator (e.g. the mass air flow detected by the MAF sensor does not decrease when the EGR valve is opened), the fault detection function determines that a functional fault exists.

On-board Diagnostic System

Monitoring Strategy for PCM

- The components of the PCM (e.g. EEPROM, RAM) are monitored for functional integrity by the PCM-internal hardware and software. Many of these diagnostic routines are performed when the ignition is switched on or when the engine is running. Other routines that require a considerable amount of processing capacity (e.g. diagnostic routines for the EEPROM) are carried out during the power-latch phase of the PCM. This prevents the diagnostic routines from interfering with other PCM operations.

Fail-safe Function

- The fail-safe function is integrated in the PCM and ensures the drivability of the vehicle during the occurrence of a fault. Different fail-safe strategies are used for sensors and actuators.

Fail-safe Strategy for Sensors

- If a fault is detected on a sensor for which fail-safe data is stored in the PCM, the fail-safe function reverts to a constant substitute value for engine control. In order to prevent any further damage the fail-safe function will always provide a “safe” substitute value. As a result, then the vehicle can be driven without major restrictions.
- If e.g. the ECT sensor is faulty, the PCM uses the engine coolant temperature of the cold engine (e.g. 0 °C) for engine control to ensure that the engine operates properly even at low ambient temperatures. In addition, the cooling fan is activated permanently to prevent the engine from overheating.

NOTE: If the fail-safe function uses a constant substitute value due to a faulty sensor, this value is also displayed when monitoring the calculated value (e.g. temperature, pressure etc.) of the corresponding PID with WDS. In order to prevent mis-diagnosis the voltage value of the PID concerned should be monitored as well. If e.g. an open circuit exists on the ECT sensor, the PID **ECT (Temp)** displays a value of 0 °C (= substitute value) but the PID **ECT (Volt)** indicates a value of 4.9 V (= open circuit).

- If a fault is detected in a sensor for which no fail-safe data is stored in the PCM, the fail-safe function goes into a limp home mode. Depending on the sensor affected then the vehicle can be driven either with reduced driving comfort or with limited power output.

Fail-safe Strategy for Actuators

- If a fault is detected on an actuator, the fail-safe function deactivates the corresponding control circuit and goes into a limp home mode. Depending on the actuator affected then the vehicle can be driven either with reduced driving comfort or with limited power output.
- If e.g. the fuel metering valve is faulty, the PCM deactivates the control circuit of the valve. In addition, the injection amount is reduced to protect the fuel system against excessive pressure, limiting the engine speed to 1800 min^{-1} .

NOTE: The fail-safe function might also deactivate the control circuit of an actuator, when an input signal required for actuator control is faulty. In order to rule out a faulty actuator, perform a simulation test with WDS. If the actuator can be controlled via WDS, check the relevant input signals for malfunctions.

On-board Diagnostic System

European On-board Diagnostics

General

- The European Union is introducing progressively stricter emissions legislation to achieve a long-lasting reduction in air pollution from vehicle emissions. As part of this legislation, all new Diesel passenger vehicles requiring type approval from January 1st 2003 must be equipped with the **EOBD** (**E**uropean **O**n-**B**oard **D**iagnostics) to monitor exhaust emissions. In addition, all Diesel passenger vehicles first registered from January 1st 2004 must meet the EOBD regulations.
- The EOBD system uses no additional sensors or actuators to measure the pollutants in the exhaust gas. It is integrated in the PCM and generally uses the existing sensors and actuators of the engine management system plus special software. These check the emission-relevant systems and components while the vehicle is traveling, and calculate the exhaust emissions accordingly.
- If any changes that significantly deteriorate exhaust emissions are detected, the MIL is illuminated. This is to alert the driver to the fact that the vehicle is potentially producing more emissions than it should, and the cause should be investigated as soon as reasonably practicable.

Type Approval and Testing

- According to the EOBD regulations the operation of the EOBD system must be guaranteed over the entire life of the vehicle. To obtain type approval for the European market, a vehicle must comply with the specified exhaust emission limits for at least 80,000 km (vehicles with Euro 3 emission standard) / 100,000 km (vehicles with Euro 4 emission standard) or five years (whichever comes first).
- Compliance of mass production vehicles with the specified exhaust emission limits will be monitored in future by the authorities. Therefore, vehicles with various mileages will undergo random testing. If these checks reveal that the specified limits are exceeded systematically, the vehicle manufacturer will be held responsible. This may lead to costly recalls or restrictions to the type approval.

On-board Diagnostic System

- The EOBD limits are always slightly higher than the exhaust emission limits of the Euro 3 emission standard, i.e. minimal overshooting of the Euro 3 limits still does not lead to an activation of the MIL.

	CO (g/km)	HC (g/km)	NO _x (g/km)	HC + NO _x (g/km)	PM (g/km)
Euro 3	0.64	-	0.5	0.56	0.05
Euro 4	0.5	-	0.25	0.3	0.025
EOBD	3.2	0.4	1.2	-	0.18

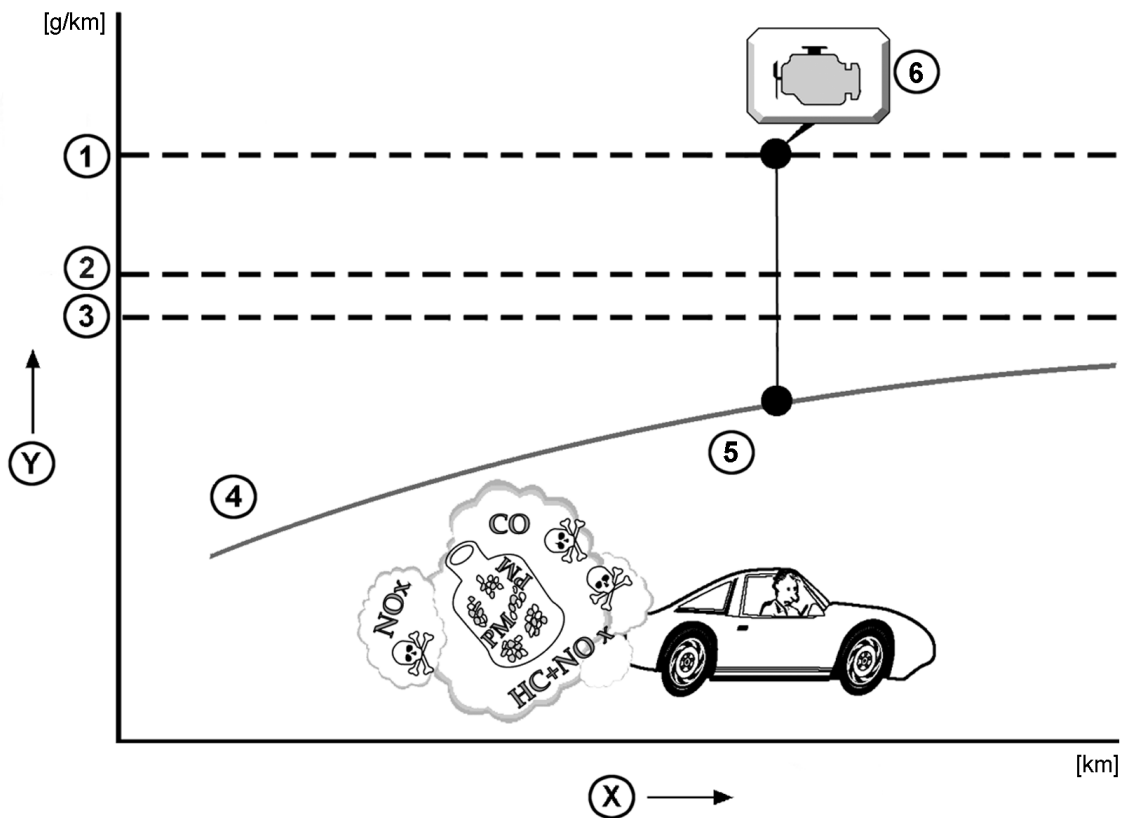

E49789

- | | | | |
|---|---|---|---|
| X | Mileage | Y | Exhaust emissions |
| 1 | Exhaust emission limits of EOBD | 4 | Actual exhaust emissions of the vehicle |
| 2 | Exhaust emission limits of Euro 3 emission standard | 5 | Emission-relevant fault |
| 3 | Exhaust emission limits of Euro 4 emission standard | 6 | MIL activated |

On-board Diagnostic System

Definitions

- The following definitions are important to understand the operation of the EOBD system.

Drive Cycle

- According to the EOBD regulations a drive cycle consists of engine start up, engine operation where a malfunction would be detected if present, and engine shut off.

NOTE: A drive cycle starts when the engine exits from the "Engine Start" state and is completed when the ignition is switched off and the power latch phase of the PCM has ended. However, if the ignition is switched back on during the power latch phase the drive cycle is not completed.

Warm-up Cycle

- According to the EOBD regulations a warm-up cycle consists of engine start up and sufficient engine operation, so that the engine coolant temperature has risen at least 22 °C from engine starting and reaches a minimum temperature of 70 °C.

Monitors

- The so called monitors are diagnostic routines carried out by the PCM in order to detect malfunctions of the emission-relevant systems and components. On Mazda Diesel engines continuous and non-continuous monitors are used.
- Continuous monitors operate permanently, i.e. the correct function of a system/ component is checked permanently during one drive cycle.

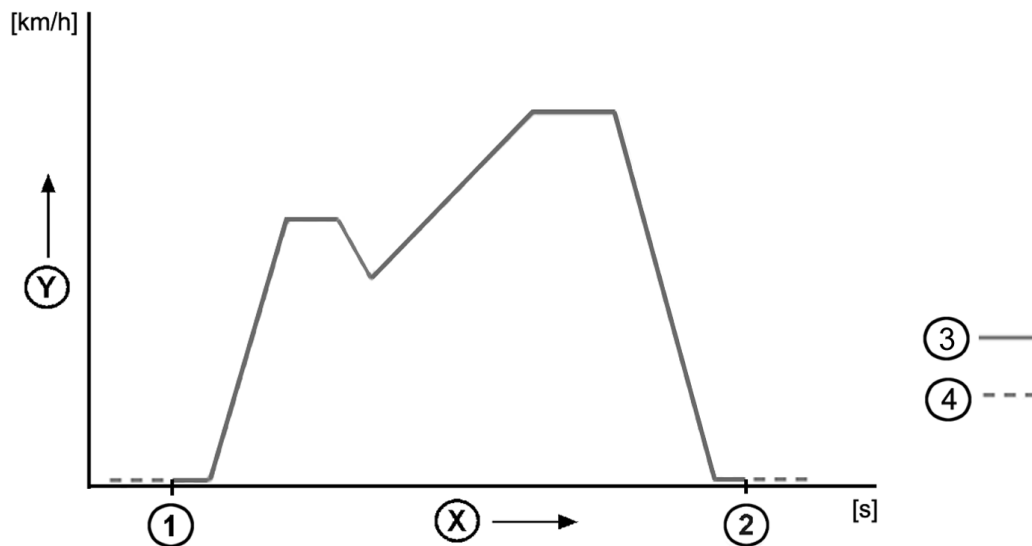

CM3004

X	Time	Y	Vehicle speed
1	Engine start	3	Monitor operative
2	Ignition OFF	4	Monitor inoperative

- The continuous monitors are activated after engine start and operate until the ignition is switched off.

On-board Diagnostic System

- Non-continuous monitors operate intermittently, i.e. the correct function of a system/ component is checked only once during a drive cycle, when suitable operating conditions exist.

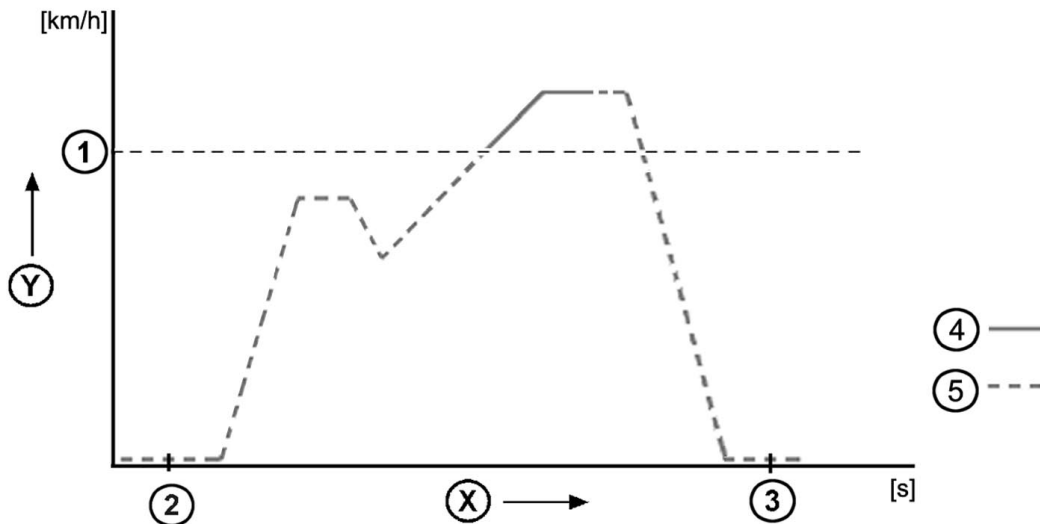

N-CM3004

X	Time	Y	Vehicle speed
1	Vehicle speed when the monitoring conditions are met	4	Monitor operative
2	Engine start	5	Monitor inoperative
3	Ignition OFF		

- The non-continuous monitor is activated as soon as the particular engine operating conditions exist, and the respective tests are carried out in a certain order. If the required operating conditions are no longer met during the monitoring phase, the monitoring is stopped and the data collected so far is frozen. After regaining the operating conditions during the same drive cycle, the monitoring is continued. In case the operating conditions are not met again during the same drive cycle, monitoring starts anew during the next drive cycle.
- When the monitoring is completed and no fault has occurred, the monitor is deactivated. As a result, a fault occurring in the system after the monitor has been deactivated will only be detected during the next drive cycle.
- If a fault is detected during the monitoring phase, the system/component concerned and the monitor are switched off until the next time the engine is started. In case the fault also affects the operation of other monitors, these are switched off as well. As a result, storage of subsequent faults is prevented.

On-board Diagnostic System

- The EOBD system for Mazda Diesel engines comprises the following monitors:
 - Comprehensive component monitor
 - Fuel system monitor
 - EGR system monitor

Comprehensive Component Monitor

- The **CCM (Comprehensive Component Monitor)** continuously checks the emission-relevant sensors and actuators for open circuit, short circuit, range faults and plausibility faults. If an emission-relevant component fails, this is recognized by the monitor and a fault is stored in the PCM memory.
- The CCM only monitors those emission-relevant sensors and actuators, which are not checked by another monitor. In addition, the monitor checks components that are used for other monitors but do not affect the exhaust emissions.

Fuel System Monitor

- The fuel system monitor continuously checks the injection amount and injection timing actuator(s) of the fuel system for open circuit, short circuit and functional faults. If a fuel system-related component fails, this is recognized by the monitor and a fault is stored in the PCM memory.
- On common rail systems the injection amount is monitored via the injectors and the fuel pressure sensor, while the injection timing is determined with the aid of the CKP sensor.
- On the Denso injection pump system the injection amount is monitored via the spill valve, while the injection timing is determined with the aid of the pump speed sensor.

EGR System Monitor

- The EGR system monitor intermittently checks the components of the EGR system for open circuit, short circuit and functional faults. If an EGR system-related component fails, this is recognized by the monitor and a fault is stored in the PCM memory.
- On systems without EGRVP sensor, the EGR system is monitored solely via the MAF sensor.
- On systems with EGRVP sensor, the EGR system is monitored via the MAF sensor and the EGRVP sensor.

On-board Diagnostic System

Temporary Disablement of Monitors

- According to the EOBD regulations temporary disablement of individual monitors is permitted under certain conditions to prevent mis-diagnosis and hence incorrect malfunction indication by the EOBD system. The monitors can be disabled during:
 - Vehicle operation with a fuel tank level below 20 %
 - Vehicle operation at elevations over 2500 m above sea level
 - Engine start at ambient temperatures below -7 °C

Monitor Status

- The monitor status provides information whether the individual monitors have completed their tests at least once. It can be checked with WDS via Mode 1, which enables monitoring of emission-related PIDs, supported monitors and their completion status.

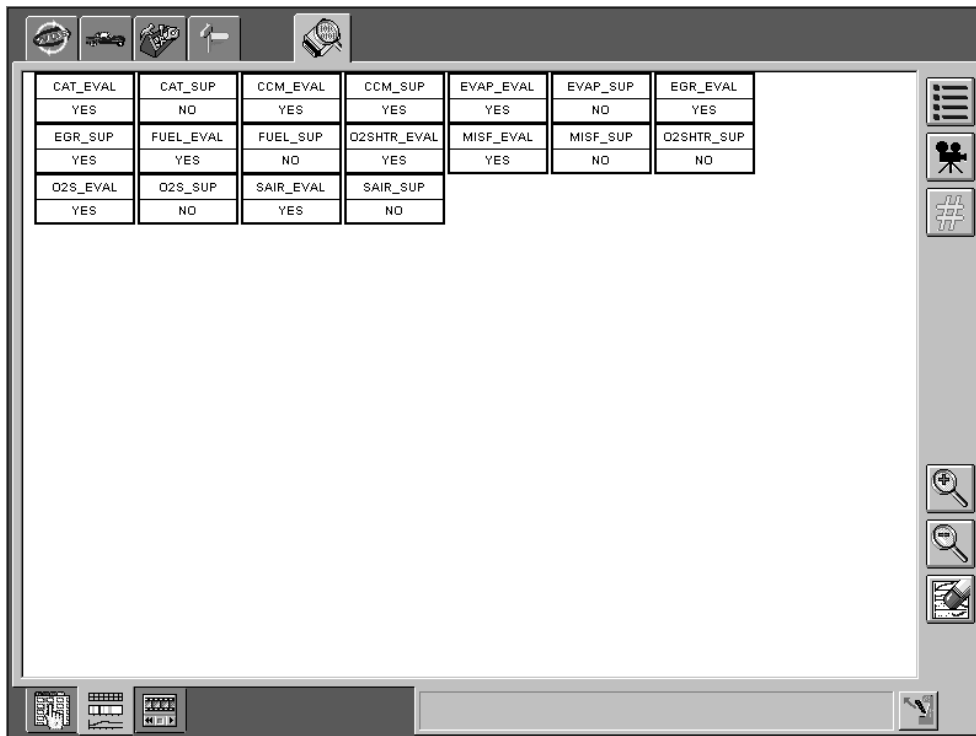

The screenshot shows a diagnostic tool interface with a table of monitor status data. The table has 7 columns and 4 rows of data. The interface includes a top toolbar with icons for various diagnostic functions, a right-hand sidebar with navigation icons, and a bottom status bar.

CAT_EVAL	CAT_SUP	CCM_EVAL	CCM_SUP	EVAP_EVAL	EVAP_SUP	EGR_EVAL
YES	NO	YES	YES	YES	NO	YES
EGR_SUP	FUEL_EVAL	FUEL_SUP	O2SHTR_EVAL	MISF_EVAL	MISF_SUP	O2SHTR_SUP
YES	YES	NO	YES	YES	NO	NO
O2S_EVAL	O2S_SUP	SAIR_EVAL	SAIR_SUP			
YES	NO	YES	NO			

M6 Mode1

On-board Diagnostic System

- The monitors supported by the EOBD system can be checked with the aid of the PIDs with the ending "_SUP". If e.g. the PID **EGR_SUP** is set to "YES", the EGR system monitor is supported by the EOBD system. Monitors that are set to "NO" are generally not supported and can be disregarded.
- The completion status of the monitors can be checked with the aid of the PIDs with the ending "_EVAL". If e.g. the PID **EGR_EVAL** is set to "YES", the tests of the EGR system monitor have been completed.

NOTE: For monitors that are not supported by the EOBD system the PIDs with the ending "_EVAL" are automatically set to "YES". If e.g. the evaporative system monitor is not supported on Mazda Diesel engines, the PID **EVAP_SUP** is set to "NO" and the PID **EVAP_EVAL** is set to "YES". This is to prevent technicians from mis-interpreting that the tests of this monitor have not been completed yet.

- CCM and fuel system monitor run continuously and therefore always display "YES" for the completion status. The intermittently operating EGR system monitor only displays "YES", if the respective tests have been completed at least once.
- For non-continuous monitors the completion status is reset and changed back to "NO" when clearing the DTCs with WDS. Then the OBD drive mode must be performed, so that these monitors can complete their tests.
- If "NO" is displayed for a non-continuous monitor, the following reasons should be considered:
 - No monitoring has been performed since the vehicle was manufactured.
 - No monitoring has been run since the PCM memory was last reset.
 - A fault has been detected during the first monitoring.
- The monitor status and other EOBD-related PIDs can be checked with WDS via the option **Toolbox→Powertrain→OBD Test Modes→Mode 1 Powertrain Data**.

On-board Diagnostic System

MIL Activation and Fault Storage

- The conditions for MIL activation and fault storage largely depend on the vehicle type. Generally the MIL only comes on when a fault is stored in the PCM memory as a confirmed fault. If the fault does not reoccur during three drive cycles, the MIL is extinguished in the fourth drive cycle. However, the fault remains stored in the PCM memory. Faults that no longer occur are automatically deleted from the PCM memory after 40 warm-up cycles.
- In addition, the MIL is extinguished when the related fault is cleared with WDS.

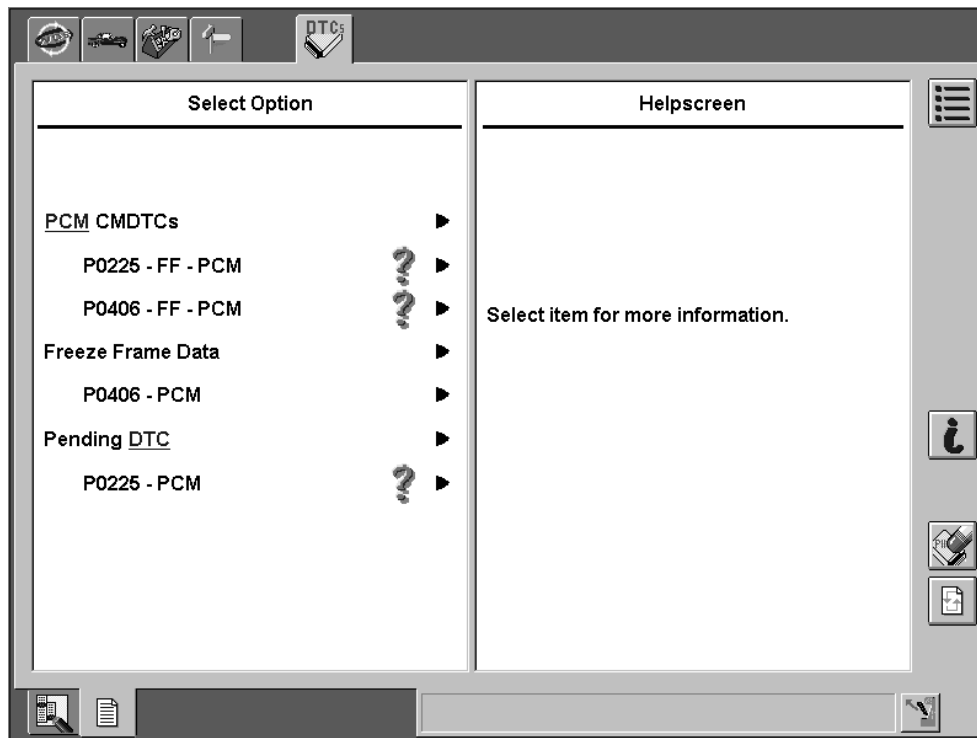

M6 pen mil

- If the MIL illuminates, the customer is not legally obliged to do anything, but the fault that caused the MIL to illuminate may result in the vehicle failing a regular emission test. However, the customer is advised to take the vehicle to an authorized Mazda workshop as soon as possible.
- In addition, the EOBD system records the distance traveled since the MIL was illuminated. Thus a check can be made on how long a customer took to have an emission-relevant fault repaired. This may become important in warranty issues and therefore should be noted on the repair order.
- The distance traveled since activation of the MIL can be checked with the aid of the PID **MIL_DIS** (Meter), which can be called up with WDS via the option **Toolbox**→**Powertrain**→**OBD Test Modes**→**Mode 1 Powertrain Data**.

On-board Diagnostic System

- On Mazda vehicles with 2.0 MZR-CD engine and RF-T engine the MIL is activated either after one drive cycle or after two drive cycles.
- MIL activation after one drive cycle is used for faults for which fail-safe data is stored in the PCM. If such a fault comes up, the PCM reverts to the fail-safe data (e.g. substitute values) for engine control. As a result, a fault occurring for the first time is stored in the PCM memory directly as a confirmed fault (= MIL DTC). Consequently the MIL is illuminated.

	DC		DC	DC	DC	DC		DC	DC	WUC	DC
	1	Monitoring conditions not met	2	1	1	2	Monitoring conditions not met	3	1	40	1
Fault	Yes	Yes	Yes	Yes	No	→						
MIL DTC	Stored	→	Stored								→	Erased
MIL	ON	→	ON						→	OFF		

DC: Drive cycle
WUC: Warm-up cycle

DC1

On-board Diagnostic System

- MIL activation after two drive cycles is used for faults for which no fail-safe data is stored in the PCM. If such a fault comes up, the PCM goes into a limp home mode (e.g. engine speed limitation). As a result, a fault occurring for the first time is stored in the PCM memory as a presumed fault (= pending DTC), but the MIL is not illuminated. If the fault is not confirmed during the second drive cycle, the PCM judges that the system/component has returned to normal operation or that the fault was detected by mistake, and deletes the presumed fault.

	DC		DC	DC	DC	DC		DC	DC		WUC	DC
	1	Monitoring conditions not met	2	1	1	2	Monitoring conditions not met	3	1		40	1
Fault	Yes	Yes	No	→								
Pending DTC	Stored	→	Stored	Erased	→							
MIL DTC	No	→	No	→								
MIL	OFF	→	OFF	→								

DC: Drive cycle
WUC: Warm-up cycle

DC3

- However, if such a fault is confirmed during the second drive cycle, the PCM judges that the system/component has failed, and automatically changes the presumed fault to a confirmed fault. As a result, the MIL is illuminated.

	DC		DC	DC	DC	DC		DC	DC		WUC	DC	
	1	Monitoring conditions not met	2	1	1	2	Monitoring conditions not met	3	1		40	1	
Fault	Yes	Yes	Yes	Yes	No	→							
Pending DTC	Stored	→	Erased	→									
MIL DTC	No	→	Stored	→								Erased	
MIL	OFF	→	ON	→					OFF	→			

DC: Drive cycle
WUC: Warm-up cycle

DC2

On-board Diagnostic System

- On Mazda vehicles with 1.4 MZ-CD engine and 1.6 MZ-CD engine the MIL is generally activated after three drive cycles. As a result, a fault occurring for the first time is stored in the PCM memory as a presumed fault, but the MIL is not illuminated. If the fault is not confirmed during the second drive cycle, the PCM judges that the system/component has returned to normal operation or that the fault was detected by mistake, and deletes the presumed fault (also refer to MIL activation after two drive cycles).
- However, if such a fault is confirmed during the second and the third drive cycle, the PCM judges that the system/component has failed, and automatically changes the presumed fault to a confirmed fault in the third drive cycle. As a result, the MIL is illuminated.

	DC		DC	DC	DC	DC	DC		DC	DC	WUC	DC	
	1	Monitoring conditions not met	2	3	1	1	2	Monitoring conditions not met	3	1	40	1	
Fault	Yes	Yes	Yes	Yes	Yes	No	→							
Pending DTC	Stored	→		Erased	→									
MIL DTC	No	→		Stored	→								Erased	
MIL	OFF	→		ON	→					OFF				

DC: Drive cycle
WUC: Warm-up cycle

DC4

- The pending DTCs and the MIL DTCs can be read out and cleared with WDS via the option **Toolbox→Selftest→Modules→PCM→Retrieve CMDTCs**.

NOTE: Depending on the vehicle type pending DTCs may not be displayed by WDS.

NOTE: When the DTCs are cleared, the freeze frame data and the distance traveled since activation of the MIL are cleared as well. In addition, the completion status of the non-continuous monitors is reset.

On-board Diagnostic System

Freeze Frame Data

- The **FFD (Freeze Frame Data)** is a snapshot of the engine operating conditions at the occurrence of the first fault. This data is stored in the PCM memory and will not be overwritten, even if a presumed fault is changed to a confirmed fault. The only exception is a fault related to the fuel system since these faults have a higher priority. If such a fault is stored in the PCM memory, this FFD will overwrite any old data, unless the previous FFD are also related to the fuel system.

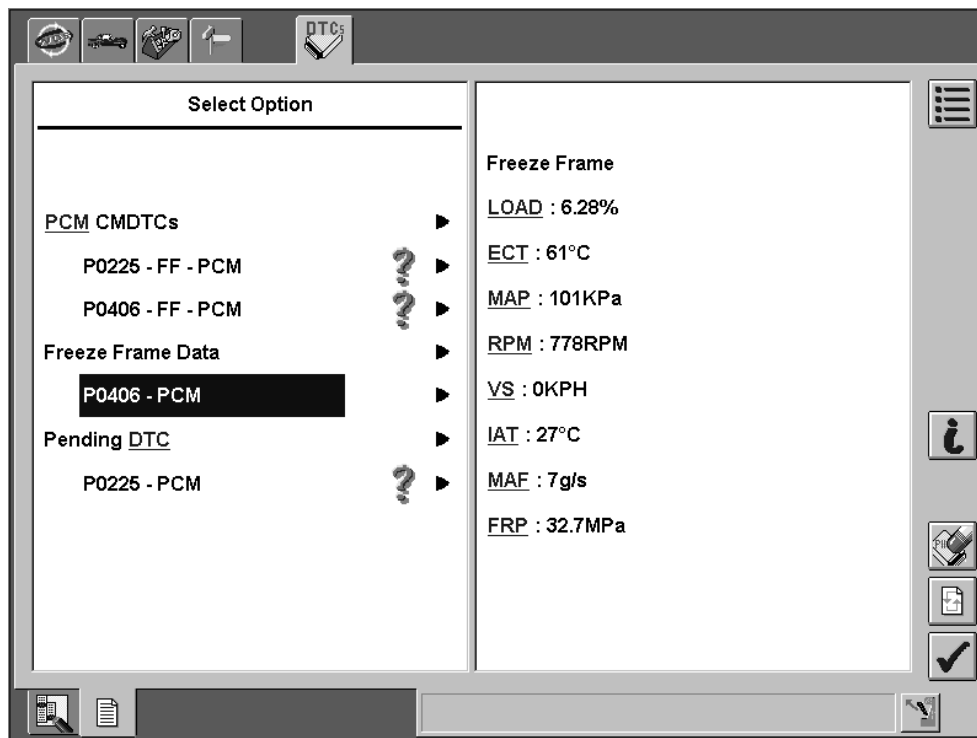

M6 pen mil ffd

- The FFD is very helpful when diagnosing the potential causes of a malfunction. In addition, a concern can be reproduced easier by driving the vehicle under the same conditions as indicated by the FFD.

On-board Diagnostic System

- When a fault is detected, the following data is stored in the PCM memory:

FFD	Description
ECT	Engine coolant temperature
FRP	Fuel rail pressure
IAT	Intake air temperature
LOAD	Calculated engine load
MAF	Mass air flow
MAP	Manifold absolute pressure
RPM	Engine speed
VS	Vehicle speed

- The FFD can be read out with WDS via the option **Toolbox→Selftest→Modules→PCM→Retrieve CMDTCs**.

NOTE: Depending on the vehicle type FFD may not be displayed by WDS.

On-board Diagnostic System

Tamper Protection

- According to the EOBD regulations the PCM must have a write-protection for any reprogrammable computer code to prevent tampering (such as unauthorized reprogramming etc.). The data of the tamper protection and the VIN (if stored in the PCM memory) can be checked with WDS via Mode 9.
- The **CALID** (**CAL**ibration **ID**entification) identifies the specific calibration and is defined as a 16-digit alphanumeric code providing information about calibration name, type of vehicle, release date, release engineer and version number. The **CVN** (**CAL**ibration **V**erification **N**umber) serves to verify whether the correct software is stored in the PCM and is similar to an encrypted checksum. CALID and CVN will be tracked for all initial releases, running changes and field fixes of the PCM software.

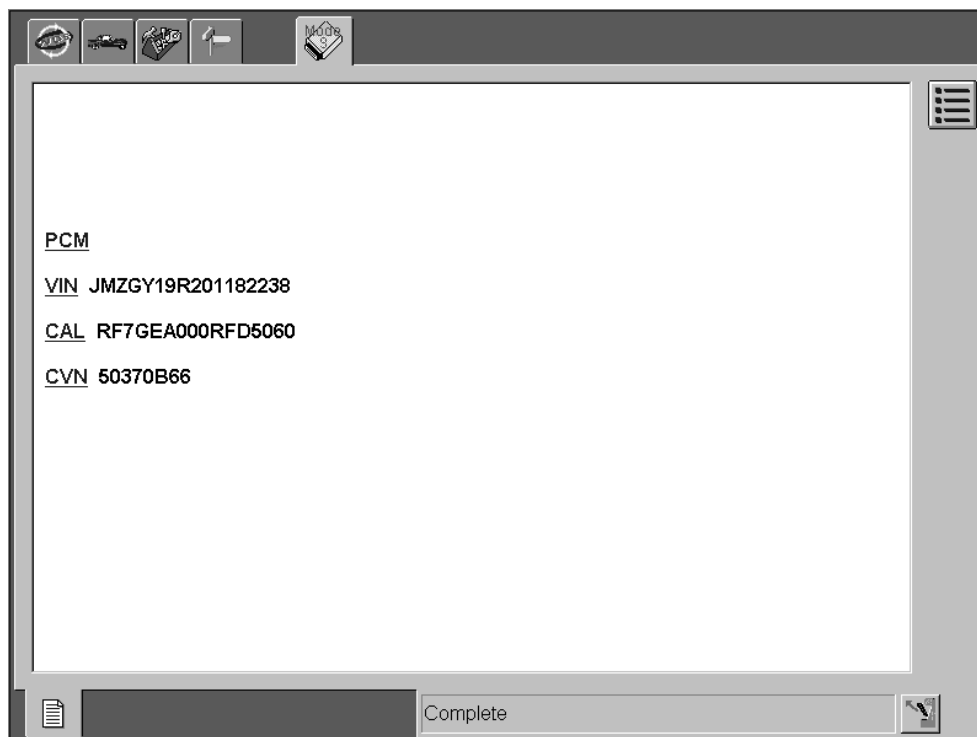

M6 Mode9

- The CALID, CVN and VIN can be read out with WDS via the option **Toolbox**→**Powertrain**→**OBD Test Modes**→**Mode 9 Vehicle Information**.

On-board Diagnostic System

Diagnostics

- When performing diagnosis and repair of EOBD-related concerns the basic procedure shown below should be followed.

NOTE: Failure to follow this procedure will make it extremely difficult to properly diagnose and repair EOBD-related concerns.

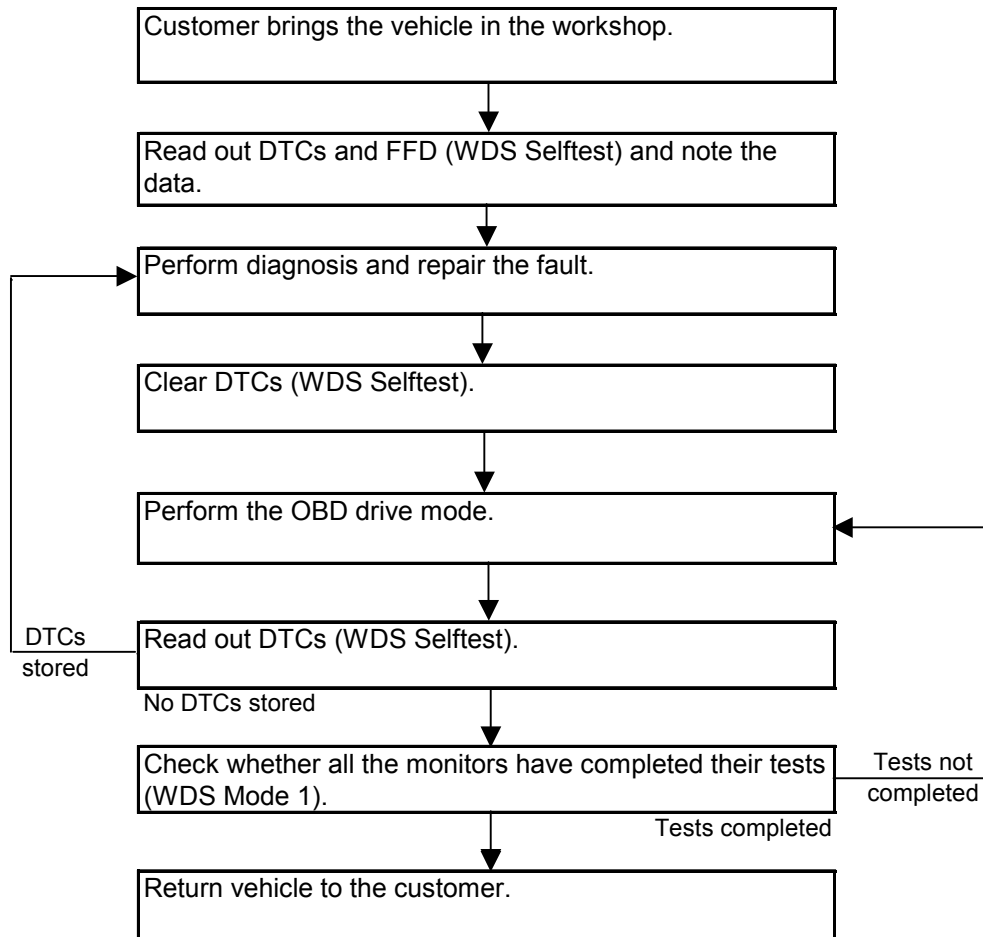

EOBD

On-board Diagnostic System

OBD Drive Mode

- The OBD drive mode is designed so that all the monitors can conduct and complete their tests in a logical order and hence in the fastest possible way. It should be performed after EOBD-related repairs to ensure that the vehicle is in order.

NOTE: The tests of the monitors can be completed faster if the accelerator pedal is moved smoothly when accelerating or decelerating. In addition, the fuel tank level should be above 20 % as otherwise the fuel system monitor might be disabled, preventing other monitors from running.

- E.g. the OBD drive mode for Mazda6 GG/GY and MPV LW with 2.0 MZR-CD must be performed as following:
 - Bring the engine to normal operating temperature and verify that all accessory loads (A/C, headlights, blower motor, rear window defroster) are off.
 - Drive the vehicle five times according to the drive mode indicated in the figure on a road with 0 % gradient. Do NOT shut off the engine between each of the five drive modes.

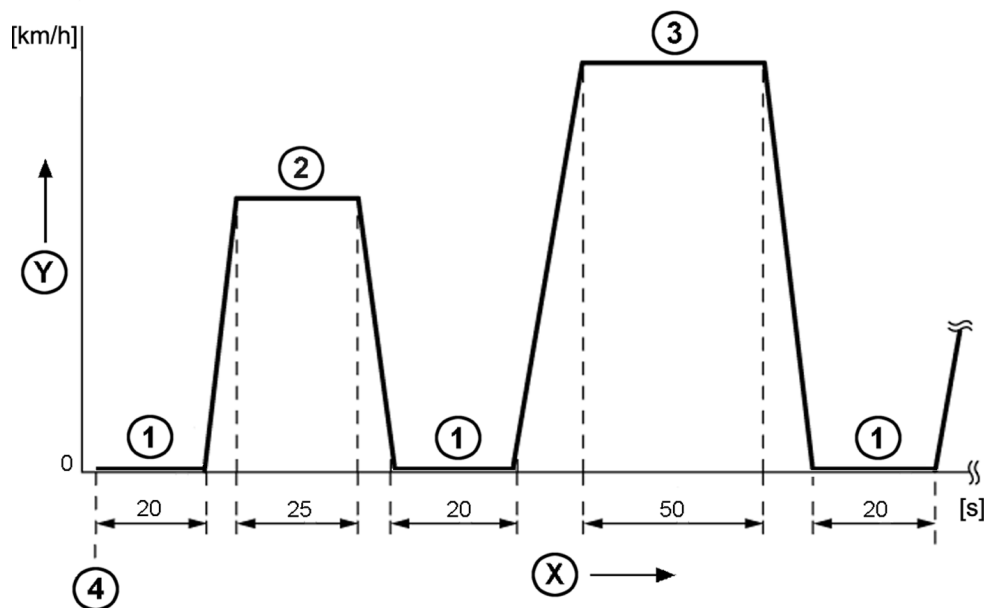

B6E4070W078

X	Time	Y	Vehicle speed
1	Idle	3	Above 50 km/h (3rd gear)
2	Above 35 km/h (2nd gear)	4	Engine start

Notes

Engine Mechanical System

Engine Mechanical System

General

- While the various sub-systems of the Mazda common rail and injection pump systems (such as intake-air system, fuel system, emission system and control system) have already been covered in the course “Basic Diesel Engine Management” and in the preceding sections, this section describes the engine mechanical system.
- The following parameters of the engine mechanical system can affect the running of a diesel engine:
 - Compression pressure
 - Valve timing
 - Valve clearance

Compression Pressure

- A sufficiently high compression pressure ensures that the temperature in the combustion chamber is high enough for the diesel fuel to auto-ignite and burn completely.
- Insufficient compression pressure can occur due to worn piston rings, worn valves or a leaking cylinder head gasket. This can lead to hard engine start or no start (particularly with cold engine), black smoke and poor engine power.

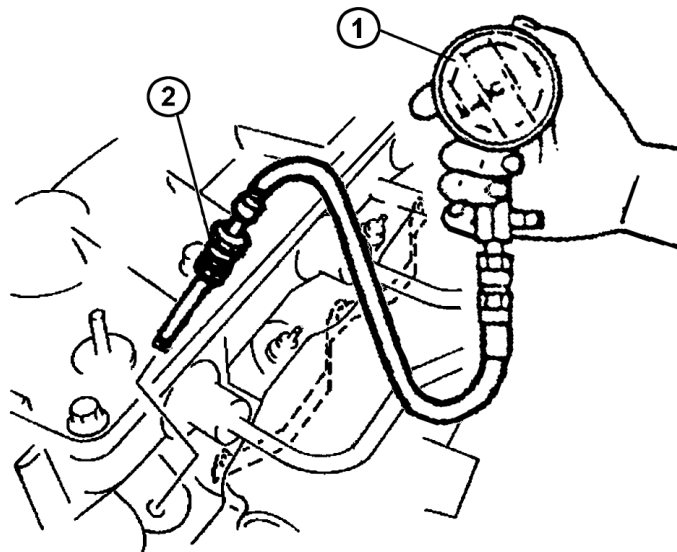

A6E2314W101

1 Compression pressure tester

2 Adapter

Valve Timing

- The correct valve timing ensures that the valves open and close at the right time to provide good cylinder charging and optimum compression pressure.
- Incorrect timing can occur if the camshaft pulley is not aligned correctly or if the timing belt has jumped over. This can lead to loud engine noise, poor engine power, increased exhaust emissions, or engine damage due to contact between the piston and the valves.

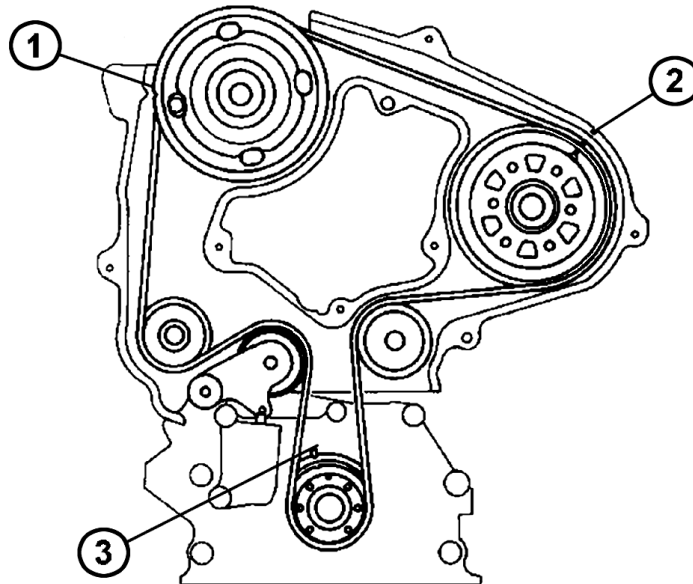

A6E2316W103

1 Timing mark for camshaft

2 Timing mark for high-pressure pump

3 Timing mark for crankshaft

Engine Mechanical System

Valve Clearance

- The correct valve clearance ensures that the valves open wide enough to provide good cylinder charging and at the same time close fully to ensure an optimum compression pressure.
- Incorrect valve clearance can occur due to wear and thermal loading of the valves. On engines with hydraulic valve clearance compensation, faulty hydraulic lash adjusters can also cause incorrect valve clearance. This can lead to poor engine power, noise from the valve gear, or burnt valves due to insufficient heat transfer to the cylinder head.

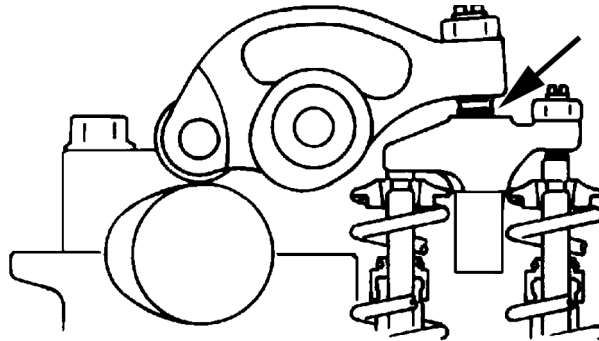

A6E2312W101

Diagnostics

- The engine mechanical system can be checked as following:
 - Checking the compression pressure
 - Checking the pressure loss
 - Checking the valve timing
 - Checking the valve clearance

Checking the pressure loss

- If the compression pressure of a cylinder is found to be too low, the pressure loss test can be used to locate the leak in the combustion chamber and to establish which components are faulty. The principle is that the combustion chamber is pressurized with compressed air and the loss of pressure arising due to the leak is indicated by a flowing noise. For this, the piston must be in TDC position and the valves closed. Then a compressed air hose is connected with a suitable adapter to the glow plug or injector opening of the cylinder concerned.
- If the compressed air is escaping through a valve, flowing noises will be audible in the intake or exhaust system. Loss of pressure past the piston rings into the crankcase can be identified by flowing noises from the oil filler opening. Flowing noises in another cylinder or bubbling in the cooling system indicates a leaking cylinder head gasket.

Diagnostic Process

Diagnostic Process

General

- Diagnosis requires a complete knowledge of the system operation. As with all diagnosis, a technician must use symptoms and clues to determine the cause of a customer concern. The following diagnostic process provides you with a logical method for rectifying customer concerns:
 1. Confirm the symptom of the customer concern.
 2. Determine which system of the vehicle could be causing the symptom.
 3. Once you identify the particular system, determine which component(s) within that system could be the cause for the customer concern.
 4. After determining the faulty component(s) you should always try to identify the cause of the failure. In some cases components just wear out. However, in other cases something else than the failed component is responsible for the problem.

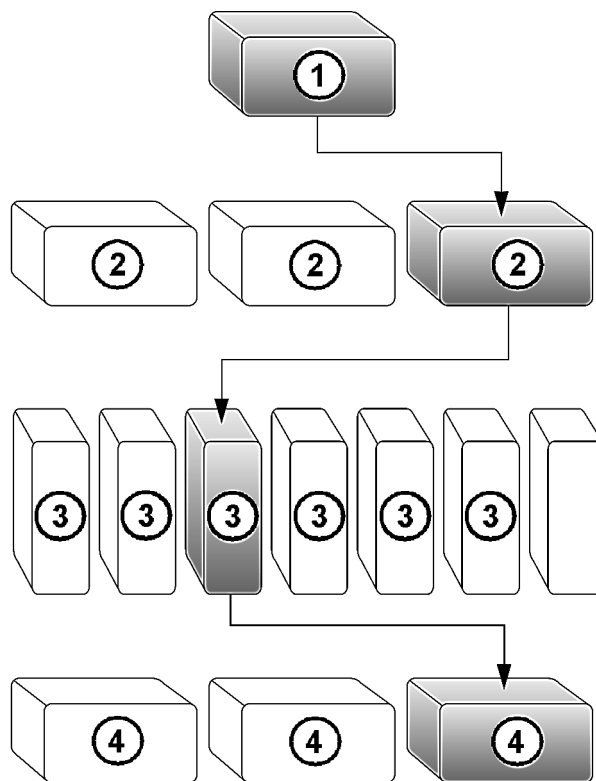

ELEC107A

1 Symptom
2 Systems

3 Components
4 Causes

- For example, a customer's car is brought in the workshop with a "No start" concern, i.e. the symptom is that the engine will not start. During diagnosis you find that the fuel pressure in the common rail is too low. Therefore, you determine that the system affected by the problem is the fuel system. By performing diagnostic routines, you determine that the high-pressure pump is the faulty component. Further investigation finds that the cause of the component failure is contamination in the fuel tank.

Basic Checks for Troubleshooting

- When performing troubleshooting on a diesel engine the following basic checks should be made before moving on to more complex electrical checks.

NOTE: When the customer complains about "No start" or "Hard start", check that the engine starting procedure has been carried out correctly (incl. pre-heating). If this is okay, spray "Start Pilot" into the intake-air duct while cranking the engine. If the engine starts, the fuel system might be faulty. If the engine does not start, then this indicates a fault in the engine mechanical system.

Engine Mechanical System

- Check the compression.
- Check the pressure loss.
- Check the valve timing.
- Check the valve clearance.
- Check the engine oil for contamination (e.g. by diesel fuel, coolant).
- Check the coolant for contamination (e.g. by engine oil, diesel fuel).

Intake-air System

- Check the condition of the air cleaner.
- Check the intake-air system for leakage or oil ingress.
- Check the turbocharger.
- Check the function of the boost pressure control valve (turbocharger with FGT).
- Check the function of the guide vanes (turbocharger with VGT).

Diagnostic Process

Fuel System

- Check whether the fuel tank contains sufficient diesel fuel.
- Check the diesel fuel for contamination (e.g. by particles, water, petrol).
- Check the fuel system components for leakage.
- Check the fuel lines for leakage or kinks.
- Check the fuel system for air ingress.
- Check the fuel filter for blockage (e.g. due to precipitation of paraffin wax crystals).
- Check the function of the fuel tank ventilation.
- Check the start of fuel delivery (only injection pump systems).
- Check whether fuel is available at the injectors (only injection pump systems).
- Check the fuel pressure (only common rail systems).

Emission System

- Check the exhaust system for leakage.
- Check the oxidation catalytic converter for blockage.
- Check the function of the EGR system.
- Check the function of the intake shutter valve.
- Check the function of the crankcase ventilation.
- Check the exhaust emissions for smoke.

NOTE: Excessive white smoke indicates incorrect injection timing or coolant in the cylinders.
Excessive black smoke indicates incomplete combustion, which can be caused by an insufficient compression pressure, faulty injectors, a faulty turbocharger or a faulty EGR system.

Control System

- Check the function of the fuses and relays.
- Check the condition of the electrical connections incl. ground connections.
- Check the condition of the battery.
- Check the condition of the starter motor.
- Check the function of the glow plugs.

Notes

A/C	Air Conditioning	EGR	Exhaust Gas Recirculation
BDC	Bottom Dead Center	EGRVP	EGR Valve Position
CALID	Calibration Identification	EOBD	European On-Board Diagnostics
CCM	Comprehensive Component Monitor	FFD	Freeze Frame Data
CKP	Crankshaft Position	FGT	Fixed Geometry Turbine
CMDTC	Continuous Memory DTC	FHA	Fuel Hose Adapter
CO	Carbon Monoxide	FLT	Fuel Temperature
CSP	Control Sleeve Position	FSOV	Fuel Shut-Off Valve
CVN	Calibration Verification Number	HC	Hydro Carbon
DC	Direct Current	IAT	Intake Air Temperature
DLC	Data Link Connector	IDM	Injector Driver Module
DTC	Diagnostic Trouble Code	ISV	Intake Shutter Valve
ECT	Engine Coolant Temperature	MAF	Mass Air Flow
		MAP	Manifold Absolute Pressure

List of Abbreviations

Adv. Diesel Engine Management

MIL	M alfunction I ndicator L ight	VIN	V ehicle I dentification N umber
NO_x	O xides of N itrogen	VSC	V ariable S wirl C ontrol
OBD	O n- B oard D iagnostics	WDS	W orldwide D iagnostic S ystem
PCM	P owertrain C ontrol M odule		
PID	P arameter I dentification		
PM	P articulate M atter		
PROM	P rogrammable R ead- O nly M emory		
PVT	P ressure/ V acuum T ransducer		
SPV	S pill V alve		
TCV	T imer C ontrol V alve		
TDC	T op D ead C enter		
TPS	T imer P osition S ensor		
VBC	V ariable B oost C ontrol		
VGT	V ariable G eometry T urbine		