



Category No.	Literature	Ref. No. L243/05	Page 1 of 1
Coverage <input type="checkbox"/> Distributor only <input checked="" type="checkbox"/> Please inform your dealers		Date issued October 28, 2005	
Please convey this information to your <input type="checkbox"/> Warranty Dept. <input type="checkbox"/> Parts Dept. <input checked="" type="checkbox"/> Training Dept. <input checked="" type="checkbox"/> Field Rep		Attachment: 7	
Applicable Model Mazda6 MPS		Applicable Country or Specification Australian specs.	

Subject: Additions/Corrections to Service Materials

The additions and/or corrections have been made to the following service materials in response to engineering modifications and/or errors.

Attached are copies of the pages to be added or revised. Please make copies of these sheets as necessary, and attach them to the applicable pages in each manual. The material to be corrected is shown on the top of each page.

The additions and/or corrections are shown enclosed in broken lines or underlined on the revised page.

Applied Materials:

Manual Name (Form No.)	Page	Remarks
Mazda6 MPS Wiring Diagram (5659-1*-05H)	20, 34, 38, 39, 46, 54, 60	FUEL PUMP RELAY, FUEL PUMP SPEED CONTROL RELAY

*: Indicates the printing location

A: Australia, 0: Japan

Service Material Planning Group
Vehicle Service & Program Department

FUSE BOX

F-01 MAIN FUSE BLOCK

- FUEL PUMP RELAY
- CONTROL RELAY
- (FUEL PUMP RELAY)

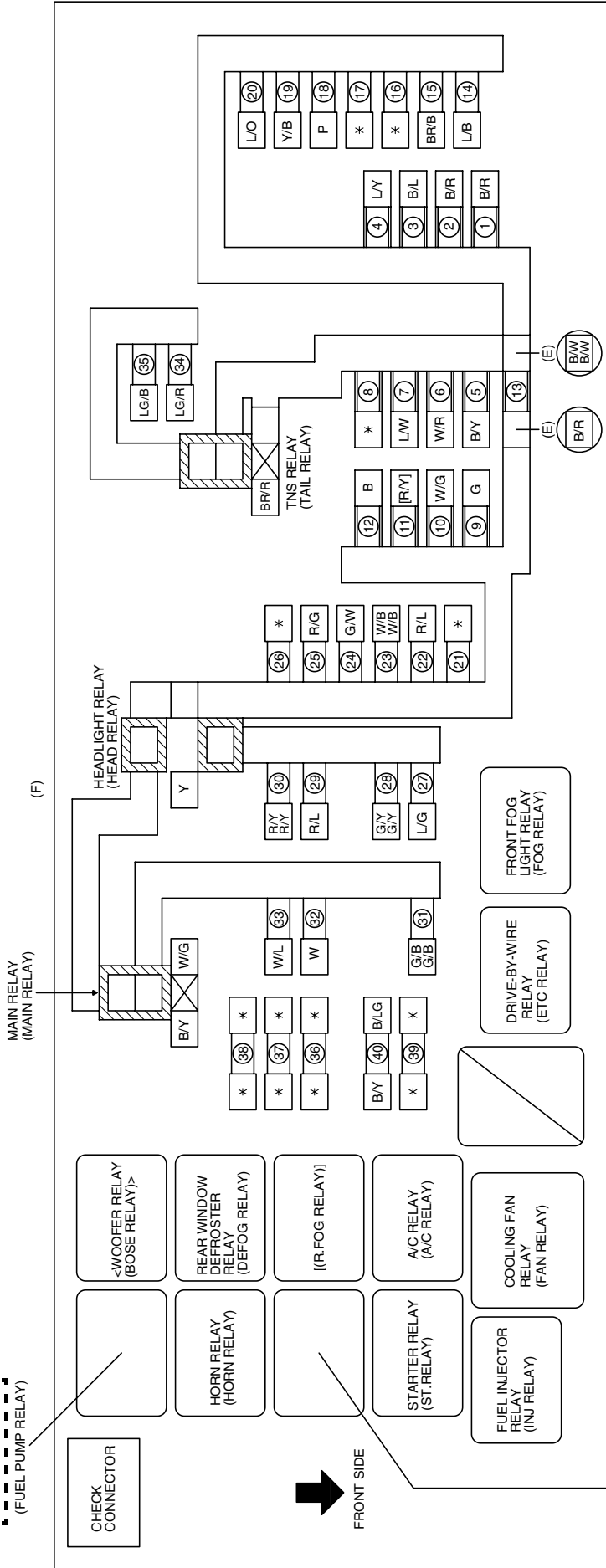

() NAME INDICATED ON FUSE BOX COVER
 <-> IF EQUIPPED
 [] NOT USED
 *: VACANT

1	FAN 1 30A	11	[P.WIND 30A]	21	—	31	ENG BB 5A
2	FAN 2 30A	12	IG KEY1 30A	22	ETC 10A	32	ENG BAR 15A
3	ABS 60A	13	MAIN 120A	23	ENG+B 10A	33	INJ 15A
4	DEFOG 40A	14	FOG 15A	24	STOP 20A	34	ILLUMI 10A
5	IG KEY2 40A	15	H/CLEAN 20A	25	HAZARD 10A	35	TAIL 10A
6	BTN 40A	16	—	26	[DRL 15A]	36	SPARE 10A
7	BLOWER 40A	17	—	27	HEAD HR 10A	37	SPARE 15A
8	—	18	<P SEAT 30A>	28	HEAD HL 10A	38	SPARE 20A
9	INJ DRIVE 30A	19	<AUDIO 15A>	29	HEAD LL 15A	39	—
10	FUEL PUMP 30A	20	MAG 10A	30	HEAD LR 15A	40	M DEF 7.5A

- FUEL PUMP RELAY
- (CIRCUIT RELAY)

00D

DATA LINK CONNECTOR

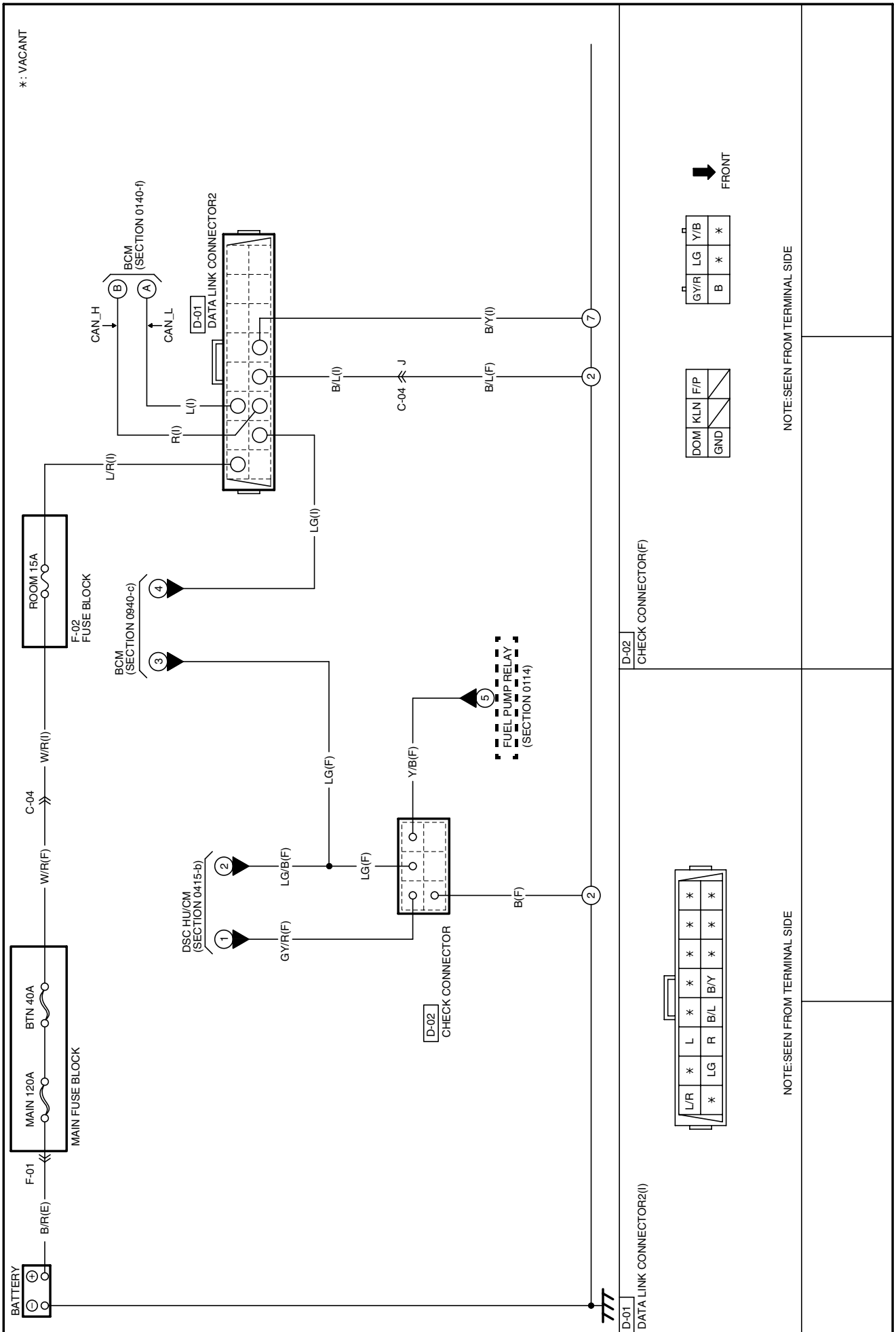

FUEL SYSTEM

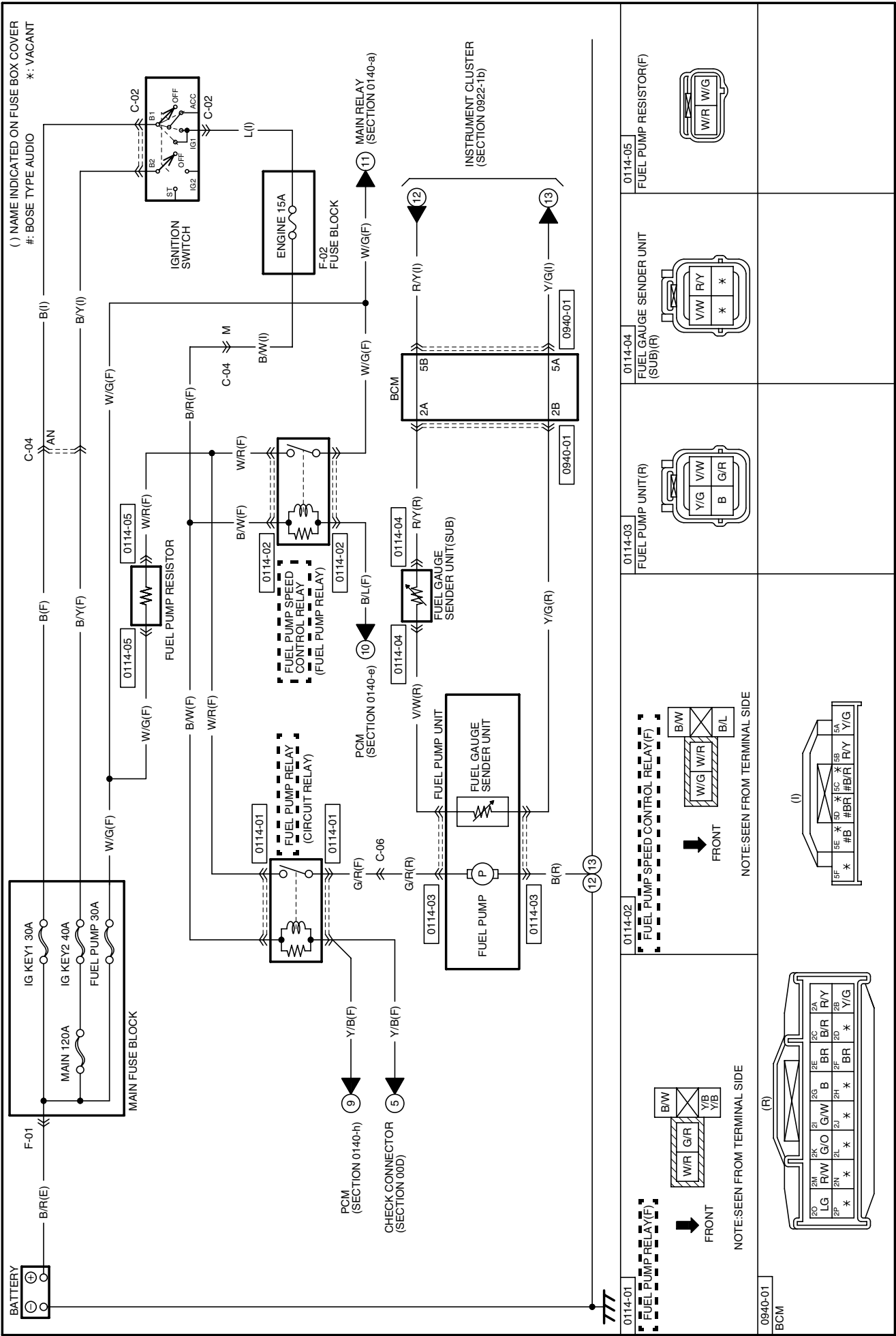

HARNES SYMBOL : (F) (E) (D) (R)

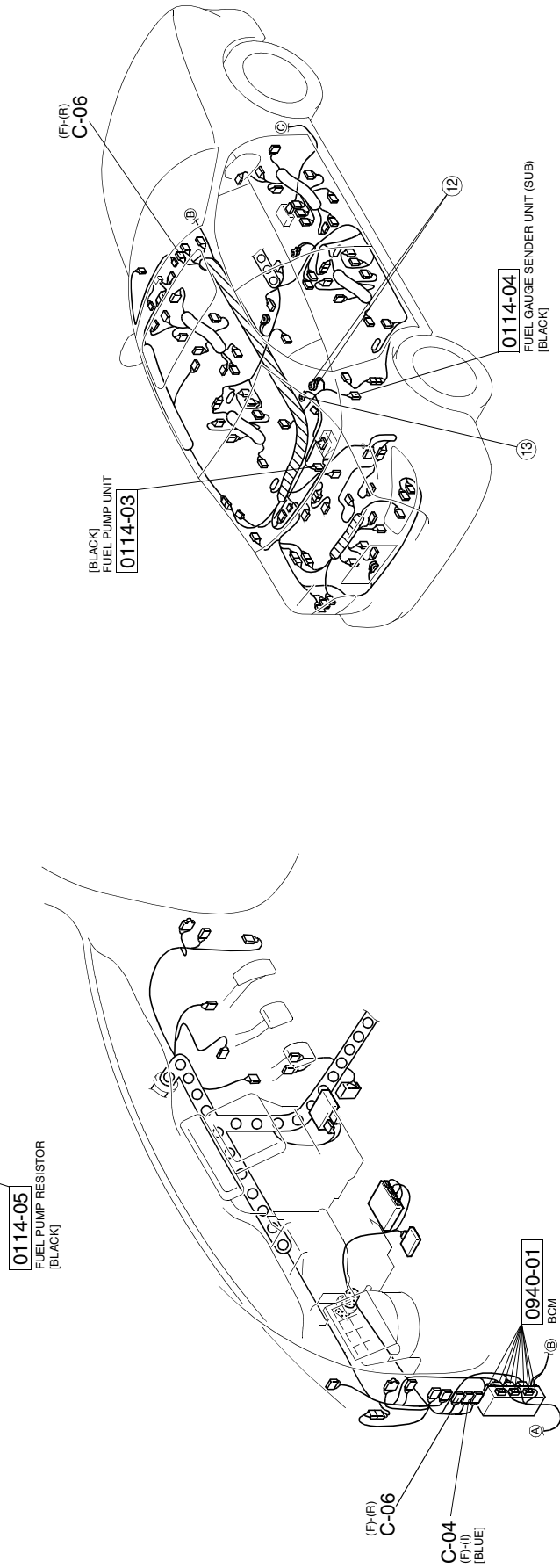
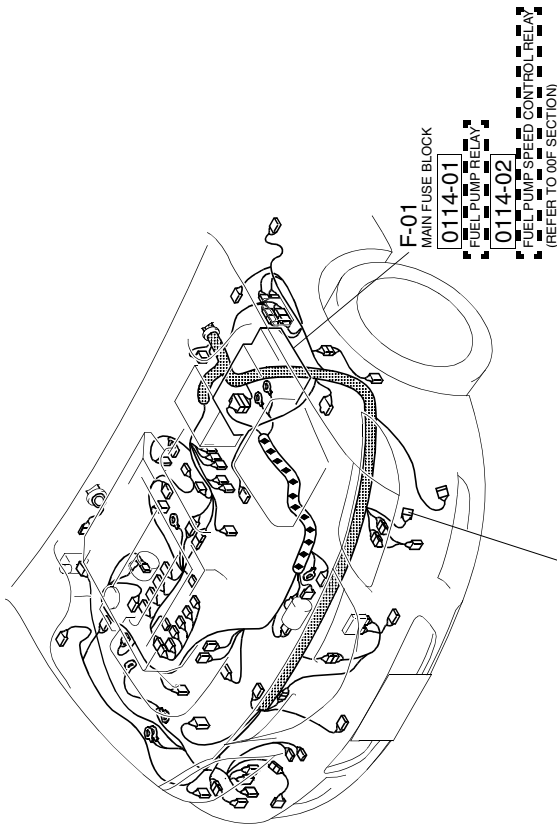
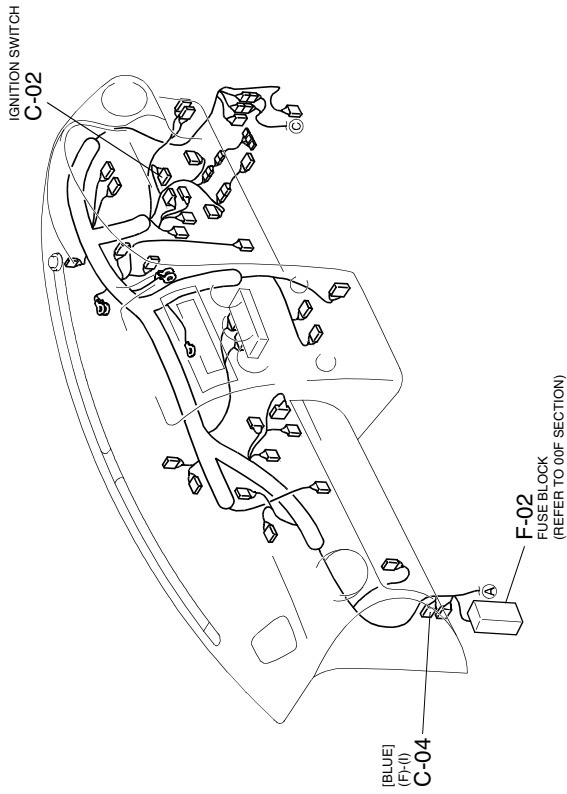

0140-a

CONTROL SYSTEM

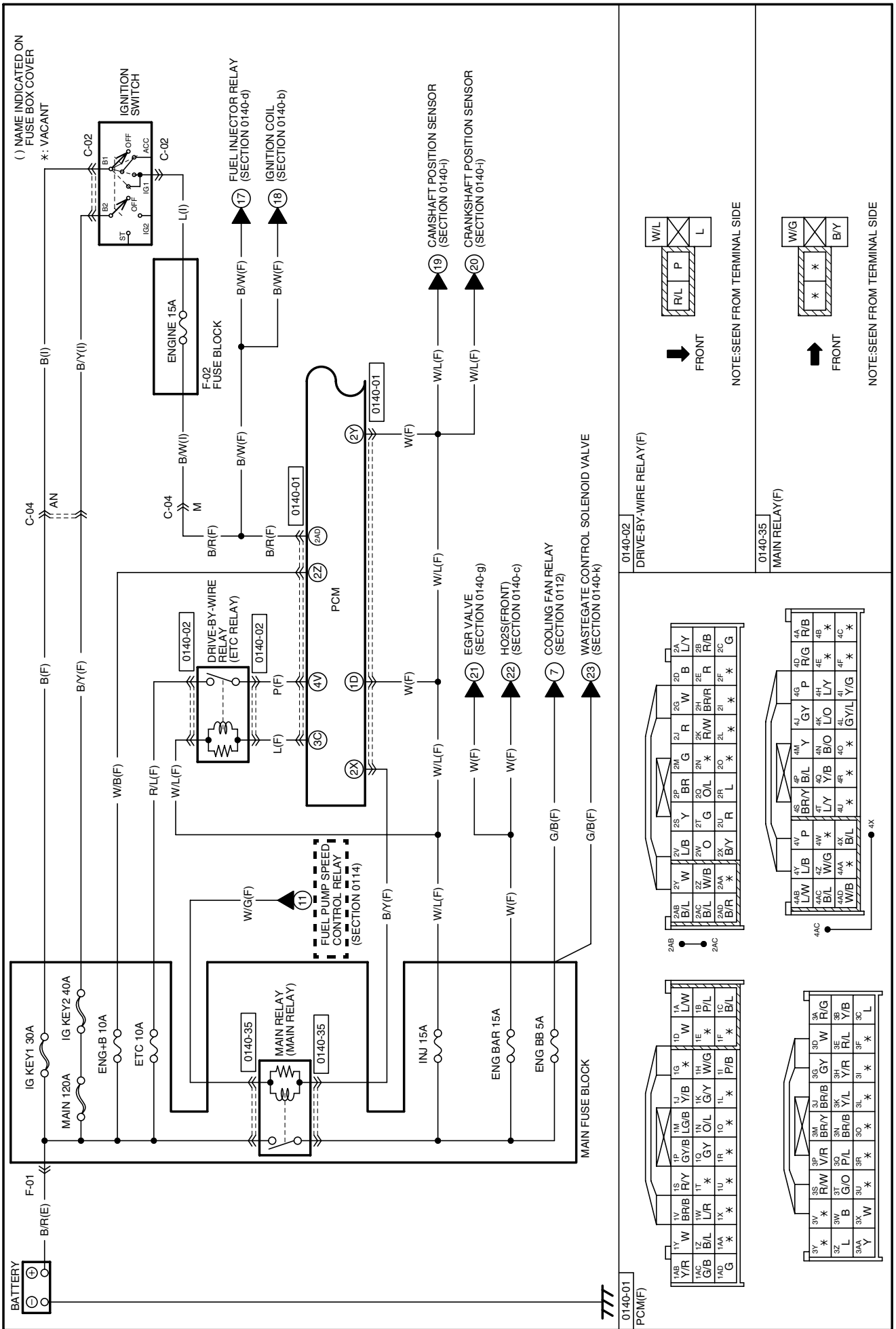

*: VACANT

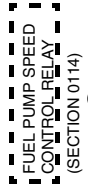
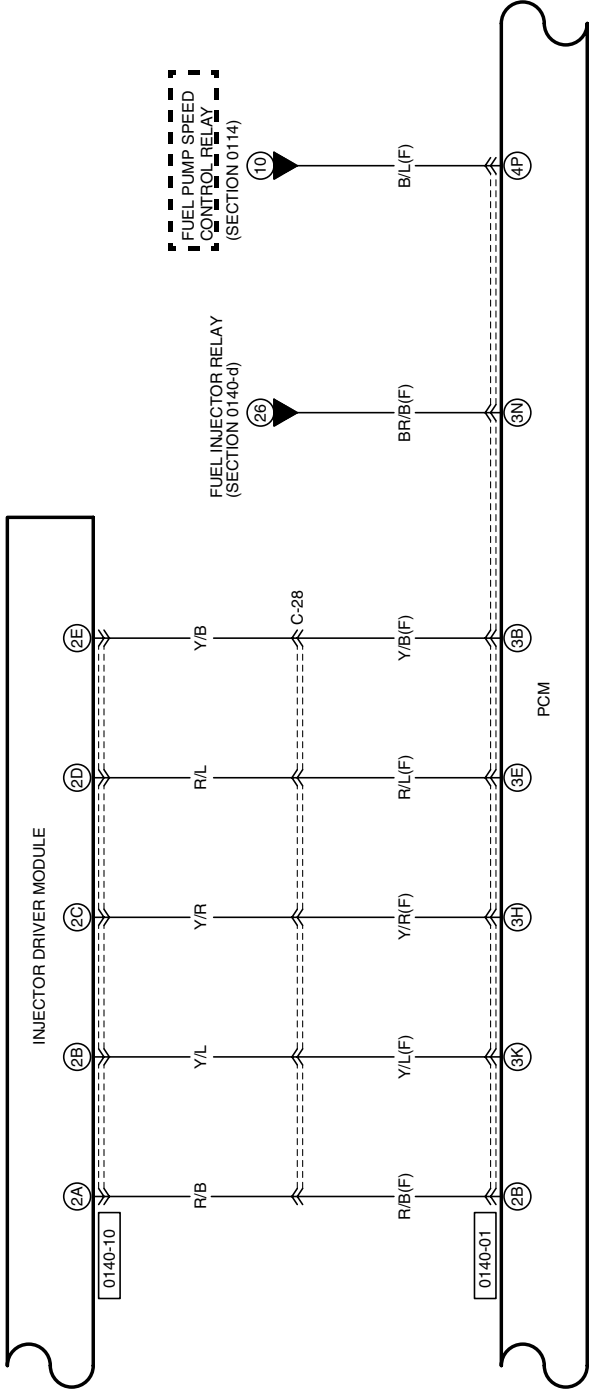

0140-01
PCM(F)

2AB	2V	2S	2P	2M	2L	2K	2J	2I	2H	2G	2F	2E	2D	2C	2B	2A
B/L	W	L/B	Y	BR	G	R	W	B	L/Y							
2AC	2Z	2W	2V	2U	2T	2S	2R	2Q	2P	2O	2N	2M	2L	2K	2J	2I
B/L	W/B	O	G	O/L	*	R/W	BR/R	R	R/B							
2AD	2A	2X	2Y	2U	2R	2L	2I	2H	2G	2F	2E	2D	2C	2B	2A	
BR	*	B/Y	R	L	*	*	*	*	*	*	*	*	*	*	*	

3Y	3V	3S	3P	3M	3J	3G	3D	3A								
*	*	R/W	V/R	BR/Y	BR/B	GY	W	R/G								
3Z	3W	3T	3O	3N	3K	3H	3E	3B	3A							
L	B	G/O	P/L	BR/B	Y/L	Y/R	R/L	Y/B								
3AA	3X	3U	3R	3O	3L	3I	3F	3C	3A							
Y	W	*	*	*	*	*	*	*								

4AB	4Y	4V	4S	4P	4M	4J	4G	4A								
L/W	L/B	P	BR/Y	B/L	Y	GY	P	R/G	R/B							
4AC	4Z	4W	4T	4O	4N	4K	4H	4E	4B							
B/L	W/G	*	L/Y	Y/B	B/O	L/O	L/Y	*	*							
4AD	4AA	4X	4U	4R	4O	4L	4I	4F	4C							
W/B	*	B/L	*	*	*	GY/L	Y/G	*	*							

0140-10
INJECTOR DRIVER MODULE(SHORT CORD)

2G	2F	2E	2D	2C	2B	2A
B/L	G/Y	Y/B	R/L	Y/R	Y/L	R/B

*: VACANT

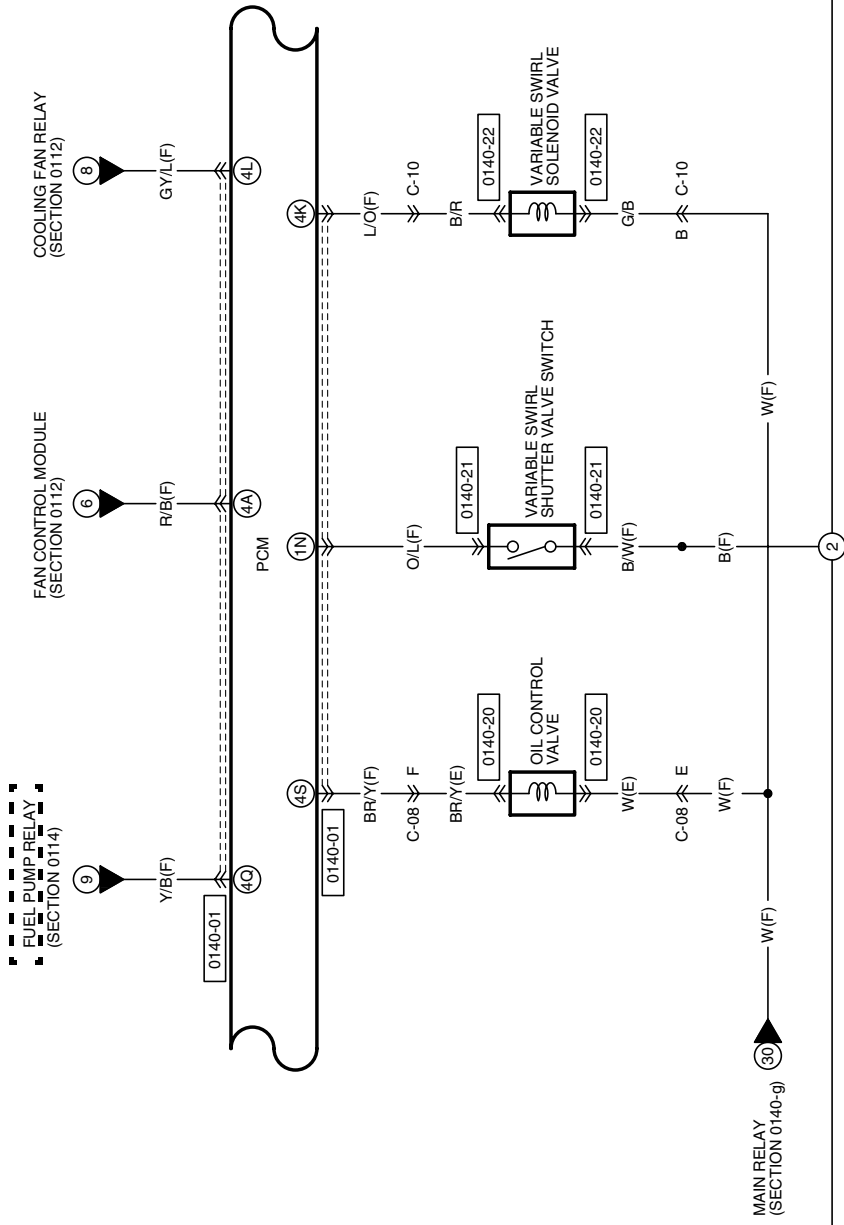

0140-01 PCM(F)	0140-20 OIL CONTROL VALVE(E)	0140-21 VARIABLE SWIRL SHUTTER VALVE SWITCH(F)	0140-22 VARIABLE SWIRL SOLENOID VALVE(SHORT CORD)																																																																																																																																																																																																																																																																																												
<table border="1"> <tr><td>1Y</td><td>Y/R</td><td>1Z</td><td>Z/B</td><td>1W</td><td>W/L</td><td>1V</td><td>V/B</td><td>1U</td><td>U/*</td><td>1T</td><td>T/*</td><td>1S</td><td>S/*</td><td>1R</td><td>R/*</td><td>1Q</td><td>Q/*</td><td>1P</td><td>P/*</td><td>1O</td><td>O/*</td><td>1N</td><td>N/*</td><td>1M</td><td>M/*</td><td>1L</td><td>L/*</td><td>1K</td><td>K/*</td><td>1J</td><td>J/*</td><td>1I</td><td>I/*</td><td>1H</td><td>H/*</td><td>1G</td><td>G/*</td><td>1F</td><td>F/*</td><td>1E</td><td>E/*</td><td>1D</td><td>D/*</td><td>1C</td><td>C/*</td><td>1B</td><td>B/*</td><td>1A</td><td>A/*</td></tr> <tr><td>4Y</td><td>Y/B</td><td>4Z</td><td>Z/W</td><td>4W</td><td>W/G</td><td>4V</td><td>V/*</td><td>4U</td><td>U/*</td><td>4T</td><td>T/*</td><td>4S</td><td>S/BRY</td><td>4R</td><td>R/Y</td><td>4Q</td><td>Q/*</td><td>4P</td><td>P/*</td><td>4O</td><td>O/B</td><td>4N</td><td>N/Y</td><td>4M</td><td>M/*</td><td>4L</td><td>L/GY</td><td>4K</td><td>K/*</td><td>4J</td><td>J/*</td><td>4I</td><td>I/*</td><td>4H</td><td>H/*</td><td>4G</td><td>G/*</td><td>4F</td><td>F/*</td><td>4E</td><td>E/*</td><td>4D</td><td>D/R/G</td><td>4C</td><td>C/*</td><td>4B</td><td>B/*</td><td>4A</td><td>A/R/B</td></tr> </table>	1Y	Y/R	1Z	Z/B	1W	W/L	1V	V/B	1U	U/*	1T	T/*	1S	S/*	1R	R/*	1Q	Q/*	1P	P/*	1O	O/*	1N	N/*	1M	M/*	1L	L/*	1K	K/*	1J	J/*	1I	I/*	1H	H/*	1G	G/*	1F	F/*	1E	E/*	1D	D/*	1C	C/*	1B	B/*	1A	A/*	4Y	Y/B	4Z	Z/W	4W	W/G	4V	V/*	4U	U/*	4T	T/*	4S	S/BRY	4R	R/Y	4Q	Q/*	4P	P/*	4O	O/B	4N	N/Y	4M	M/*	4L	L/GY	4K	K/*	4J	J/*	4I	I/*	4H	H/*	4G	G/*	4F	F/*	4E	E/*	4D	D/R/G	4C	C/*	4B	B/*	4A	A/R/B	<table border="1"> <tr><td>4AC</td><td>C/B/L</td><td>4AD</td><td>D/W/B</td><td>4AA</td><td>A/*</td><td>4AX</td><td>X/*</td><td>4AO</td><td>O/*</td><td>4AR</td><td>R/*</td><td>4AP</td><td>P/*</td><td>4AQ</td><td>Q/*</td><td>4AS</td><td>S/*</td><td>4AT</td><td>T/*</td><td>4AU</td><td>U/*</td><td>4AV</td><td>V/*</td><td>4AW</td><td>W/*</td><td>4AX</td><td>X/*</td><td>4AY</td><td>Y/*</td><td>4AZ</td><td>Z/*</td><td>4BA</td><td>A/*</td><td>4BB</td><td>B/*</td><td>4BC</td><td>C/*</td><td>4BD</td><td>D/*</td><td>4BE</td><td>E/*</td><td>4BF</td><td>F/*</td><td>4BG</td><td>G/*</td><td>4BH</td><td>H/*</td><td>4BI</td><td>I/*</td><td>4BJ</td><td>J/*</td><td>4BK</td><td>K/*</td><td>4BL</td><td>L/*</td><td>4BM</td><td>M/*</td><td>4BN</td><td>N/*</td><td>4BO</td><td>O/*</td><td>4BP</td><td>P/*</td><td>4BQ</td><td>Q/*</td><td>4BR</td><td>R/*</td><td>4BS</td><td>S/*</td><td>4BT</td><td>T/*</td><td>4BU</td><td>U/*</td><td>4BV</td><td>V/*</td><td>4BW</td><td>W/*</td><td>4BX</td><td>X/*</td><td>4BY</td><td>Y/*</td><td>4BZ</td><td>Z/*</td></tr> </table>	4AC	C/B/L	4AD	D/W/B	4AA	A/*	4AX	X/*	4AO	O/*	4AR	R/*	4AP	P/*	4AQ	Q/*	4AS	S/*	4AT	T/*	4AU	U/*	4AV	V/*	4AW	W/*	4AX	X/*	4AY	Y/*	4AZ	Z/*	4BA	A/*	4BB	B/*	4BC	C/*	4BD	D/*	4BE	E/*	4BF	F/*	4BG	G/*	4BH	H/*	4BI	I/*	4BJ	J/*	4BK	K/*	4BL	L/*	4BM	M/*	4BN	N/*	4BO	O/*	4BP	P/*	4BQ	Q/*	4BR	R/*	4BS	S/*	4BT	T/*	4BU	U/*	4BV	V/*	4BW	W/*	4BX	X/*	4BY	Y/*	4BZ	Z/*	<table border="1"> <tr><td>1Y</td><td>Y/R</td><td>1Z</td><td>Z/B</td><td>1W</td><td>W/L</td><td>1V</td><td>V/B</td><td>1U</td><td>U/*</td><td>1T</td><td>T/*</td><td>1S</td><td>S/*</td><td>1R</td><td>R/*</td><td>1Q</td><td>Q/*</td><td>1P</td><td>P/*</td><td>1O</td><td>O/*</td><td>1N</td><td>N/*</td><td>1M</td><td>M/*</td><td>1L</td><td>L/*</td><td>1K</td><td>K/*</td><td>1J</td><td>J/*</td><td>1I</td><td>I/*</td><td>1H</td><td>H/*</td><td>1G</td><td>G/*</td><td>1F</td><td>F/*</td><td>1E</td><td>E/*</td><td>1D</td><td>D/*</td><td>1C</td><td>C/*</td><td>1B</td><td>B/*</td><td>1A</td><td>A/*</td></tr> </table>	1Y	Y/R	1Z	Z/B	1W	W/L	1V	V/B	1U	U/*	1T	T/*	1S	S/*	1R	R/*	1Q	Q/*	1P	P/*	1O	O/*	1N	N/*	1M	M/*	1L	L/*	1K	K/*	1J	J/*	1I	I/*	1H	H/*	1G	G/*	1F	F/*	1E	E/*	1D	D/*	1C	C/*	1B	B/*	1A	A/*	<table border="1"> <tr><td>1Y</td><td>Y/R</td><td>1Z</td><td>Z/B</td><td>1W</td><td>W/L</td><td>1V</td><td>V/B</td><td>1U</td><td>U/*</td><td>1T</td><td>T/*</td><td>1S</td><td>S/*</td><td>1R</td><td>R/*</td><td>1Q</td><td>Q/*</td><td>1P</td><td>P/*</td><td>1O</td><td>O/*</td><td>1N</td><td>N/*</td><td>1M</td><td>M/*</td><td>1L</td><td>L/*</td><td>1K</td><td>K/*</td><td>1J</td><td>J/*</td><td>1I</td><td>I/*</td><td>1H</td><td>H/*</td><td>1G</td><td>G/*</td><td>1F</td><td>F/*</td><td>1E</td><td>E/*</td><td>1D</td><td>D/*</td><td>1C</td><td>C/*</td><td>1B</td><td>B/*</td><td>1A</td><td>A/*</td></tr> </table>	1Y	Y/R	1Z	Z/B	1W	W/L	1V	V/B	1U	U/*	1T	T/*	1S	S/*	1R	R/*	1Q	Q/*	1P	P/*	1O	O/*	1N	N/*	1M	M/*	1L	L/*	1K	K/*	1J	J/*	1I	I/*	1H	H/*	1G	G/*	1F	F/*	1E	E/*	1D	D/*	1C	C/*	1B	B/*	1A	A/*
1Y	Y/R	1Z	Z/B	1W	W/L	1V	V/B	1U	U/*	1T	T/*	1S	S/*	1R	R/*	1Q	Q/*	1P	P/*	1O	O/*	1N	N/*	1M	M/*	1L	L/*	1K	K/*	1J	J/*	1I	I/*	1H	H/*	1G	G/*	1F	F/*	1E	E/*	1D	D/*	1C	C/*	1B	B/*	1A	A/*																																																																																																																																																																																																																																														
4Y	Y/B	4Z	Z/W	4W	W/G	4V	V/*	4U	U/*	4T	T/*	4S	S/BRY	4R	R/Y	4Q	Q/*	4P	P/*	4O	O/B	4N	N/Y	4M	M/*	4L	L/GY	4K	K/*	4J	J/*	4I	I/*	4H	H/*	4G	G/*	4F	F/*	4E	E/*	4D	D/R/G	4C	C/*	4B	B/*	4A	A/R/B																																																																																																																																																																																																																																														
4AC	C/B/L	4AD	D/W/B	4AA	A/*	4AX	X/*	4AO	O/*	4AR	R/*	4AP	P/*	4AQ	Q/*	4AS	S/*	4AT	T/*	4AU	U/*	4AV	V/*	4AW	W/*	4AX	X/*	4AY	Y/*	4AZ	Z/*	4BA	A/*	4BB	B/*	4BC	C/*	4BD	D/*	4BE	E/*	4BF	F/*	4BG	G/*	4BH	H/*	4BI	I/*	4BJ	J/*	4BK	K/*	4BL	L/*	4BM	M/*	4BN	N/*	4BO	O/*	4BP	P/*	4BQ	Q/*	4BR	R/*	4BS	S/*	4BT	T/*	4BU	U/*	4BV	V/*	4BW	W/*	4BX	X/*	4BY	Y/*	4BZ	Z/*																																																																																																																																																																																																												
1Y	Y/R	1Z	Z/B	1W	W/L	1V	V/B	1U	U/*	1T	T/*	1S	S/*	1R	R/*	1Q	Q/*	1P	P/*	1O	O/*	1N	N/*	1M	M/*	1L	L/*	1K	K/*	1J	J/*	1I	I/*	1H	H/*	1G	G/*	1F	F/*	1E	E/*	1D	D/*	1C	C/*	1B	B/*	1A	A/*																																																																																																																																																																																																																																														
1Y	Y/R	1Z	Z/B	1W	W/L	1V	V/B	1U	U/*	1T	T/*	1S	S/*	1R	R/*	1Q	Q/*	1P	P/*	1O	O/*	1N	N/*	1M	M/*	1L	L/*	1K	K/*	1J	J/*	1I	I/*	1H	H/*	1G	G/*	1F	F/*	1E	E/*	1D	D/*	1C	C/*	1B	B/*	1A	A/*																																																																																																																																																																																																																																														